

# Workshop Fireproof Cable Tray Prices





## Workshop Fireproof Cable Tray Prices

---



### Trough Type Fireproof Cable Tray with Cover Price List Cable Trunking

Cable Trunking is a fully enclosed cable tray, suitable for laying computer cables, communication cables, thermocouple cables and other control cables of highly sensitive systems. It has a good effect on

[Contact Us](#)

### Trunking and cable tray protection

Our range of trunking and cable tray protection products provide effective fire protection for pipes, cables and trunking within floors, walls and ceilings.

[Contact Us](#)

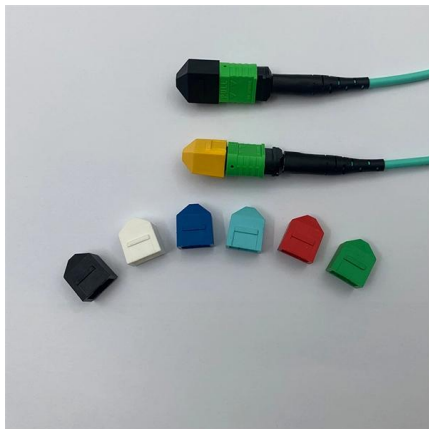

### Cable Trays & Baskets , Electrical Cable Tray Solutions

Shop our extensive range of cable baskets and trays from our selection of cable management supplies; including 100mm baskets, heavy duty cable trays, pre-galvanised cable trays, coupling baskets,

[Contact Us](#)

### Fireproof FRP Cable Tray: Durable & Safe Solution

Looking for reliable fireproof FRP cable tray? Discover top-rated, corrosion-resistant options with customization and verified suppliers. Click to explore high-performance solutions for

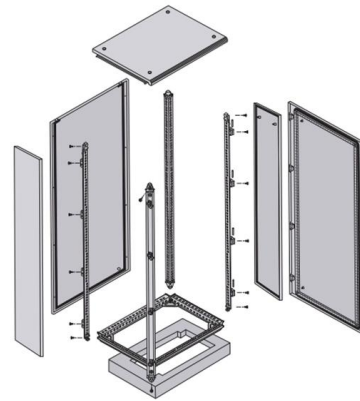

### Fireproof Stainless Steel Cable Tray for Electrical Installations

Each cable tray is individually wrapped in protective plastic to prevent scratches, then securely packed in padded cardboard boxes. We ship via reputable courier services with tracking information provided.

[Contact Us](#)

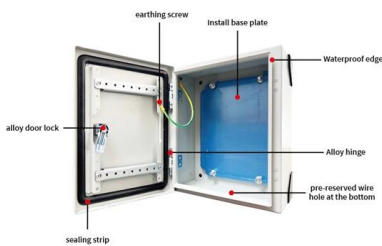

### Fire protection for cables & cable trays , Flamro

Fire protection solutions to protect cables, cable trays and cable systems. Discover our tested cable coatings and fire protection bandages!

[Contact Us](#)



### Fireproof Cable Tray for Building

Many manufacturers offer discount prices, especially for wholesale orders. Some even provide free samples for customers to test the quality of the fireproof cable trays before making a large scale

[Contact Us](#)



### Cable Trays, Fire safety solutions



The stock and the price of the product are for information only and may change during the day.

[Contact Us](#)



### Fire Rated Cable Tray

Cable tray designed to offer continuous support of cables Rated load of 12.5kg per metre over a 1.5m Span 1500mm Trapeze Support Spacing Complies with

[Contact Us](#)

### Fire Resistance Testing of Cable Trays: Key Standards

Are Your Cable Trays Fireproof? Here's How to Find Out When a fire breaks out, the last thing you want is your cable trays fueling the flames. But how

[Contact Us](#)

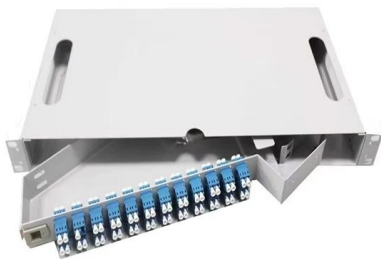
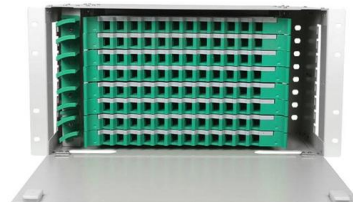

### Trunking and cable trays

Our range of trunking and cable trays products are ideal fire protection solutions for electrical services passing between walls, floors and ceilings.

[Contact Us](#)

### Fireproof Cable Trays Acceptance:



## Standards for Safety

Ensure safety and durability with this comprehensive guide to fireproof cable trays acceptance. Learn coating processes, inspection standards, and

[Contact Us](#)

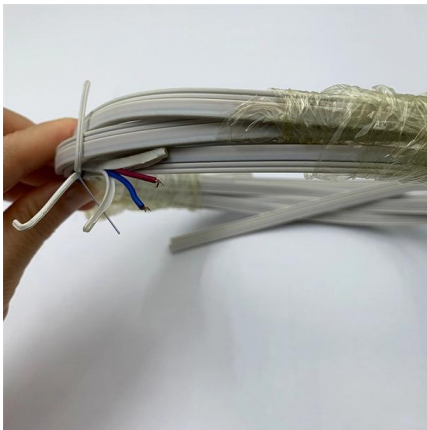

## FireMaster Cable Wrap F

FireMaster Cable Wrap is under FM Global follow-up inspection service at manufacturing locations in the Americas, Europe, and Asia, which ensures that the product received for installation meets the same

[Contact Us](#)

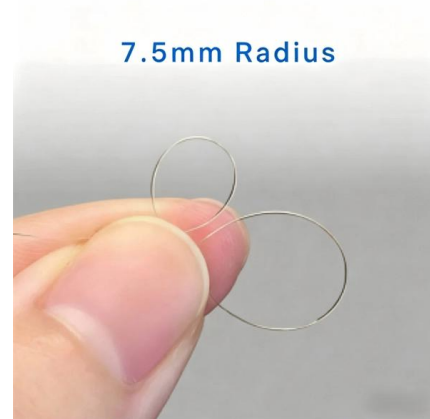

## Why Choose Fireproof Cable Trays for Safety?

Fireproof cable trays can be employed in a wide range of applications, including commercial buildings, hospitals, data centers, and even residential setups where fire safety is a

[Contact Us](#)



## FIRE RESISTANT PROOF CABLE TRAY, DIN STANDARD E90

Cablofil fire resistant and fire proof cable trays are increasingly specified in the construction, power, oil, gas, petrochem, rail and utilities industries. Cablofil cable tray has been successfully tested and

[Contact Us](#)



## Fire-Resistant Cable Trays in High-Risk Environments

Explore the importance of fire-resistant cable trays in high-risk environments. Learn about the best materials and practices to

[Contact Us](#)



## Fireproof Channel Cable Tray System

The fireproof channel cable tray system is produced by galvanized channel cable tray after processing surface treatment of a layer of fireproof coating. In addition,

[Contact Us](#)



## FIRE RESISTANT PROOF CABLE TRAY, DIN STANDARD E90

Cablofil Cable Basket - Fire Resistant Cable Tray for FP (Fire Proof) Cables Cablofil cable tray is the preferred choice for the cable containment of low and high voltage electric cables where fire

[Contact Us](#)



## Fire resistant cable tray , Hermi-solutions

Cable trays are intended for the construction of fire-resistant cable paths with surface cable laying. Cable paths are constructed as standard or lightweight cable paths.

[Contact Us](#)





## Cable Trays , Cable Management Trays

Are you looking for high-quality Cable Trays for improved cable management and organisation? Look no further than our extensive range, featuring top brands such as our very own RS PRO, Cablofil

[Contact Us](#)

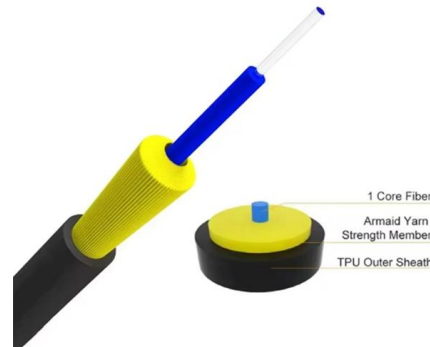

## Fireproof Cable Tray Enclosures: Keep Cabling Systems

Sinisi Solutions works with major utilities and clients to design cable enclosures that protect critical cabling and cable tray setups from heat and fire, and blasts. Sinisi

[Contact Us](#)

## Fire Rated Cable Tray, Heavy-Duty Cable Tray Manufacturer

Fire Rated Cable Trays that are crafted from premium materials like stainless steel, galvanized steel, tempered glass, and fire-resistant polyester fiberglass. Each tray is coated with a specialized fire



[Contact Us](#)

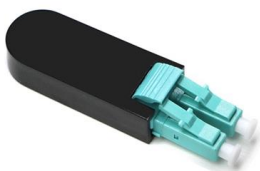

## Trunking and Cable Tray Protection

Trunking and Cable Tray Protection Fire prevention is a critical aspect of safeguarding both residential and commercial buildings. One of the essential

[Contact Us](#)



## Cable Tray Price List

The cable tray price list are for hot dip galvanized ladder type cable tray. The price is based on standard length of the cable tray which is 2.4 meters.

[Contact Us](#)

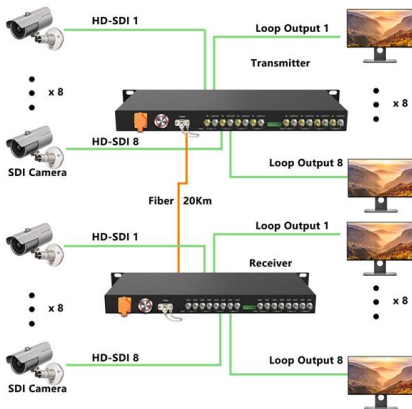

## Technical Guidelines for Cable Tray Installation and

Periodically inspect outdoor trays for rust, moisture accumulation, or UV damage reproof trays require scheduled inspection for coating integrity and

[Contact Us](#)

## Industrial Fire Proof Cable Trays

Shop high-quality fire proof cable trays for industrial and commercial use. Durable, powder-coated, and perforated for optimal ventilation and safety.

[Contact Us](#)

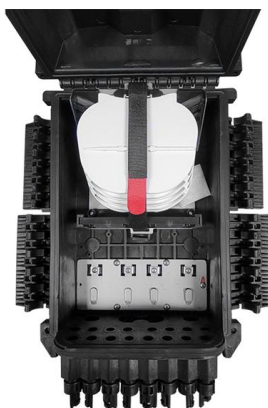

## Cable Trays , Cable Trays and Accessories , YESSS Electrical

Discover our extensive range of cable trays for the perfect office storage solution. Sourced from leading brands including Marco, Unitrunk and Pemsa, we stock a variety of light to medium-duty sizes and

[Contact Us](#)



## Contact Us

---

For datasheets, pricing, or custom fiber access solutions, please visit:  
<https://frindel.es>