

Which type of SC fiber optic cold splice is best

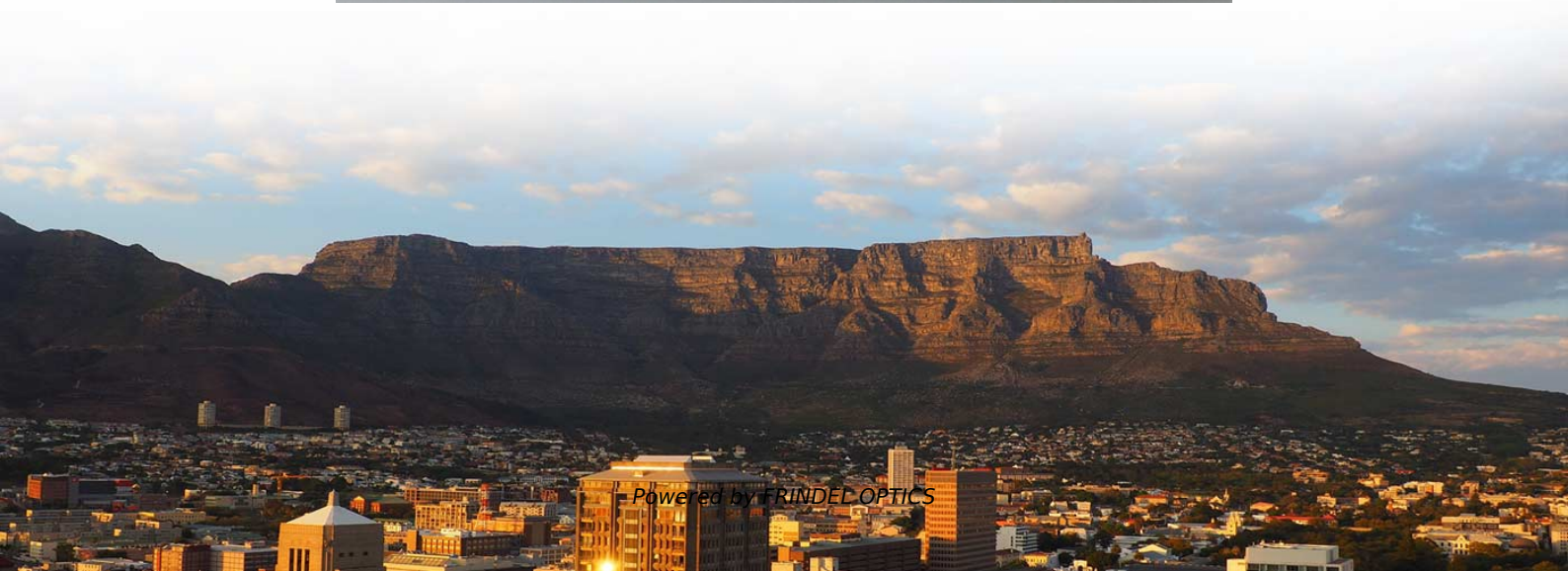



Overview

Fusion splicing is most widely used as it provides for the lowest loss and least reflectance, as well as providing the strongest and most reliable joint. A fiber fast connector, also known as a mechanical splice or cold connector, is a field-installable connector that terminates fiber optic cables without requiring a fusion splicer. Of the more than a dozen types of fibre-optic connectors available, the four most commonly used today are LC, SC, FC, and ST. They directly affect insertion loss, return loss, reliability, and long-term network stability.



Which type of SC fiber optic cold splice is best



Fiber Optic Connectors Guide: LC vs SC vs FC vs ST vs MTP/MPO - Types

Compare LC, SC, FC, ST, and MTP/MPO fiber connectors. Learn their structures, applications, advantages, and drawbacks to choose the right type for your network.

[Contact Us](#)

Fiber Optic Pigtail: The Complete Guide to Types, Splicing Methods

Confused about fiber optic pigtails--which connector type, which polish, fusion or mechanical splice? Our guide covers LC vs SC, APC vs UPC, splicing methods, and real-world use

[Contact Us](#)



Splice Closure Selection Guide for Corning Cables

The selection of the appropriate fiber optic splice closure can be a very daunting task. There are many possible ways to put two or more cables together or drop a single fiber at a location.

[Contact Us](#)

fiber optic cold connection

Fiber optic cold connection, also known as mechanical splicing, is a widely used method of connecting optical fibers in a network. Unlike fusion splicing, which uses heat to join two optical fibers

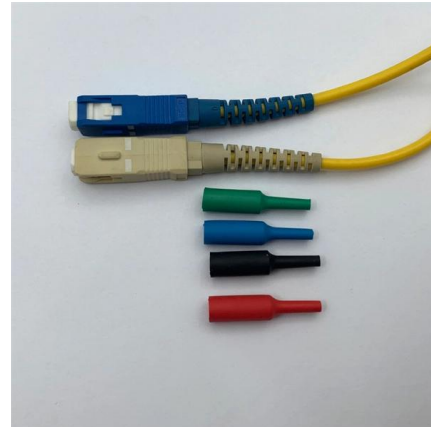

LC vs SC vs FC vs ST: A Complete Fiber Optic Connector Guide

The following guide systematically describes each connector type to help you make an informed selection for the connector that best suits your fibre-optic networking system.

[Contact Us](#)



What is Fiber Cold Splice?

What is Fiber Cold Splice? The fiber quick splicing connector is also called field assembly connector, means only use simple splicing tools not fusion splicer to realize drop cable terminated. During

[Contact Us](#)

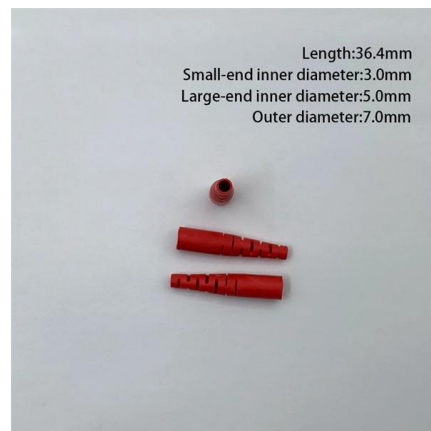

The Difference Between Optical Fiber Cold Splicing and

However, fiber cold splicing also has the following disadvantages: A higher loss will reduce signal quality; Connection quality is affected by the environment; Time is

[Contact Us](#)

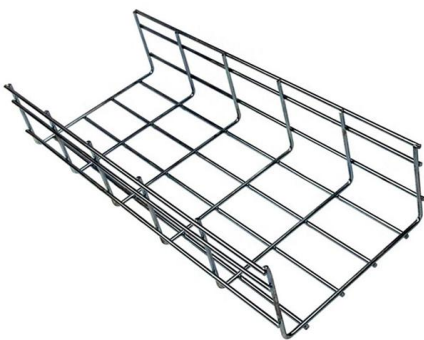



Which Fiber Optic Connector is Best for Your Network?

Fiber Patch Cables with SC connectors have a low price and greater durability. ST Fiber Optic Connector ST or Straight Tip Connector is yet another

[Contact Us](#)



Fiber optic quick connector cold joint

When inserting the optical fiber into the optical fiber quick connector/cold splice, it should be inserted slowly to prevent damage to the optical fiber, resulting in poor transmission performance of the

[Contact Us](#)

Fiber Splicing Methods and Protection with Splice Closures

Fiber optic cable splicing is the process of joining two fibers end-to-end to create a continuous optical path. In PON and FTTH networks (e.g., FTTH,

[Contact Us](#)



Advantages and disadvantages of optical fiber cold splicing compared

Efforts to reduce the splice loss at the optical fiber joint can increase the optical fiber relay amplification transmission distance and improve the attenuation margin of the optical fiber link. The

[Contact Us](#)



Complete Guide to Fiber Optic Connectors and Splicing

Learn about fiber optic connectors & splicing, types, tools, installation tips, and maintenance for reliable high-speed internet. Start optimizing today!

[Contact Us](#)



A Look at Splicing Methods , CommScope

A Look at Splicing Methods: Types, Advantages and Disadvantages The FTTH industry has grown exponentially in recent years, leading to changes in the ways that networks are being

[Contact Us](#)

Fiber SC Connectors Unveiled: Essential Guide for

Fiber SC connectors are a cornerstone of modern networking, providing efficient and reliable connections in fiber optic systems. This article

[Contact Us](#)

Mesh door/glass door optional



Sp-601 glass door

Sp-602 mesh door



The difference between optical fiber cold splicing and

There are generally two forms of cold splicing: the first field quick connector that ends up; the second type of cold splicing for optical fiber butt

[Contact Us](#)



The difference between optical fiber cold splicing and

Optical fiber transmission has the advantages of wide transmission frequency, large communication capacity, low loss, no electromagnetic

[Contact Us](#)



Optical Fiber Termination Types Chart: SC, LC, FC, ST Comparison

Compare optical fiber termination types, including SC, LC, FC, and ST. View our chart and learn how to choose the right connector for your network.

[Contact Us](#)

The FOA Reference For Fiber Optics

Splices are considered permanent joints and are used for joining most outside plant cables. Fusion splicing is most widely used as it provides for the lowest loss and

[Contact Us](#)

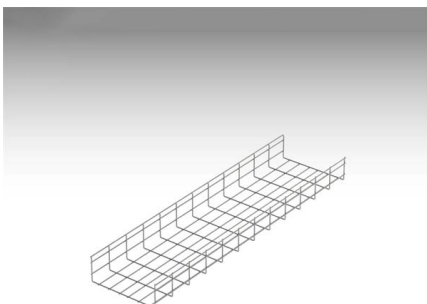

Grid Cable for marine and offshore applications

Fiber Connector Type: SC APC vs SC UPC

SC is a type of fiber optic connector with snap (push-pull coupling) coupling type and a 2.5 mm diameter ferrule, which is popularly used in single

[Contact Us](#)



Fiber Optic Connector Types: SC, LC, ST, FC, MTP/MPO , Weunion

This in-depth guide explores the technical nuances, applications, and best practices for major fiber connector types--SC, LC, ST, FC, and MTP/MPO--empowering engineers and network planners to

[Contact Us](#)



LC vs SC Fiber Connectors: Key Differences and Where

Among the most common connectors are LC and SC types, each designed for specific needs and environments. This article delves into the

[Contact Us](#)

Best SC Fiber Connectors to Upgrade Your Network in

These diverse SC fiber connectors cater to a wide range of network needs, offering flexibility and compatibility in fiber optic connections. Whether you're setting up a

[Contact Us](#)



Fiber Fast Connector Buying Guide: SC/APC Cold Connector Types

Fiber fast connectors (also called mechanical splices or cold connectors) are essential components in FTTH deployments. This comprehensive guide covers SC/APC vs SC/UPC fast

[Contact Us](#)



Best SC Fiber Connectors to Upgrade Your Network in

Final Thoughts Upgrading your network with SC fiber connectors in 2024 ensures enhanced performance and reliability. SC connectors support both single-mode

[Contact Us](#)

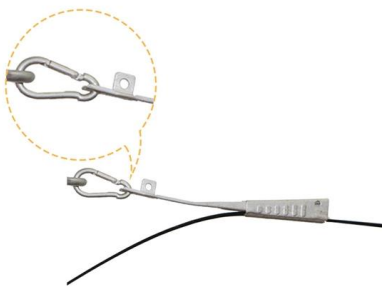

The principle of optical fiber cold splice technology

Principle of Optical Fiber Cold Splice Technology
Optical fiber cold splice technology is based on the use of mechanical connectors to join two fiber-optic cables. These connectors are

[Contact Us](#)



Pre-Terminated Patch Panel

- Multi-application support
- Flexible configuratvion
- Modular design



Understanding SC/APC Fiber Optic Connectors: A

Discover everything you need to know about SC/APC fiber optic connectors in our comprehensive guide. Learn about their applications, benefits,

[Contact Us](#)



12 port Fiber Optic Patch Panel SC LC 19? 1U Drawer Type

12 port Fiber Optic Patch Panel SC LC 19? 1U Rack Mounted Single Mode Multimode Drawer Type - Black Made of 1.2mm Premium Cold Rolled Steel Plate Supports

[Contact Us](#)



Fiber Optic Patch Panels Types Prices & Technical

Optimize your network management with our high-density Fiber Optic Patch Panels and ODFs. Available in 1U/2U/4U rack mount and wall mount configurations,

[Contact Us](#)

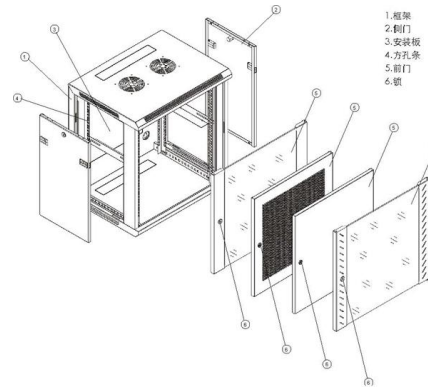

Two Types of Fiber Optic Termination: Connector and

Using connector or splicing to terminate fiber optic cables are the two main ways for fiber cross-connection and lightwave signal distribution. Check out

[Contact Us](#)

Verified Supplier Fiber Optic Distribution Panel ftth Compatible

Types of Fiber Optic Distribution Panels A fiber optic distribution panel (also known as a fiber distribution frame or FDF) serves as a centralized hub for managing, terminating, and distributing fiber optic

[Contact Us](#)



Contact Us

For datasheets, pricing, or custom fiber access solutions, please visit: <https://frindel.es>