

# **What s the best way to encapsulate a fiber Bragg grating**





## What s the best way to encapsulate a fiber Bragg grating

---

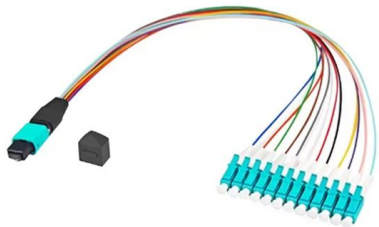

### Fiber Bragg Grating Sensors

FBG sensors can be successfully employed in structural monitoring for seismic applications and damaging diagnostics. Proper sensor packaging allows embedding in concrete for durable installation.

[Contact Us](#)



### How to inscribe a Fiber Bragg Grating?

In our Photonics lab at the Institute of Microwaves and Photonics (LHFT) we are able to inscribe our own Fiber Bragg Gratings (FBG) using an Excimer laser and the phase mask method. In this video

### Fiber Bragg Gratings: Theory, Fabrication, and Applications

The following chapters outline the operation of Bragg gratings and, for instance, discuss how measurement information can be retrieved (interrogation techniques), calibration methods, and how

[Contact Us](#)



### Fiber Bragg Grating

Fiber Bragg Grating (FBG) is defined as a sensing technology that utilizes gratings inscribed in optical fiber to enhance strain measurements by shifting the Bragg wavelength of output light in response to

[Contact Us](#)



### **Fiber Bragg Gratings: Theory, Fabrication, and Applications**

When scientists realized that the Bragg wavelength displaces with temperature and strain, FBGs started being used in the sensing world for measuring and

[Contact Us](#)



### **Capillary encapsulating of fiber Bragg grating and the associated**

Abstract In order to enhance temperature sensitivity of the bare fiber Bragg grating (FBG), a capillary encapsulating method was developed. The mechanism of temperature sensitivity

[Contact Us](#)



### **Optical Fiber Bragg Gratings , Tutorials on Electronics , Next Electronics**

An Optical Fiber Bragg Grating (FBG) is a periodic modulation of the refractive index within the core of an optical fiber. This structure acts as a wavelength-selective reflector, transmitting most

[Contact Us](#)





## What is Fiber Bragg Grating (FBG)?

A Fiber Bragg Grating is a Bragg Grating embedded within an optical fiber. Bragg grating is a reflector used in optical fibers which are constructed

[Contact Us](#)



## Bragg Gratings , How it works, Application & Advantages

Explore the world of Bragg Gratings - their principle, types, applications in telecommunications and sensing, and their promising future.

[Contact Us](#)

## Fibre Bragg Grating Sensors: An Introduction to Bragg

Fiber Bragg gratings (FBGs), as wavelength-based sensors, are made by illuminating the core of a suitable optical fiber with a spatially-varying pattern of

[Contact Us](#)



## Microsoft Word

They are formed by a periodic modulations of the index of refraction of the fiber core along the longitudinal direction and can be produced by various techniques. The term fiber Bragg grating was

[Contact Us](#)



## Fiber Bragg Grating

We have carried out a numerical simulation study to show the spectral characteristics of an FBG and various types of phase-shifted FBGs. The in-fiber Bragg gratings are modeled by the transfer matrix

[Contact Us](#)



## What Is Fiber Bragg Grating? The Ultimate Guide to

Fiber Bragg Grating enables precise strain and temperature sensing, offering reliable monitoring for structures, machines, and harsh environments.

[Contact Us](#)

## Optical Fiber Bragg Gratings , Tutorials on Electronics , Next Electronics

Optical Fiber Bragg Gratings #fiber bragg gratings #optical sensors #strain sensing #temperature sensing #telecommunications #wavelength division multiplexing #uv laser inscription #phase mask

[Contact Us](#)



## Fiber Bragg Gratings

These may be divided into two methods. The first method relies on the monitoring of either the grating as it is written or the grating just written, sequentially in small steps. The second one depends on the

[Contact Us](#)



## A Beginner's Guide to Fiber Bragg Gratings and Their Benefits

Fiber Bragg gratings (FBGs) are a specific type of Bragg grating that are written into optical fibers and used to separate different wavelengths of light and measure physical parameters in

[Contact Us](#)

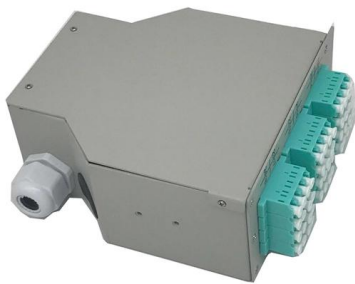

## What is a Fiber Bragg Grating? , FBG , Sensors

A Fiber Bragg Grating is just a few millimeters long, highly sensitive and very reliable. Learn more about its properties!

[Contact Us](#)

## Fabrication and Applications of Fiber Bragg Grating

Abstract: In this paper, the brief introduction of Fiber Bragg Grating, its significant applications, sensing principles, properties, fabrication and the basic designing of FBG have been discussed. FBG's are

[Contact Us](#)



## Bragg Gratings in Optical Fibers: Fundamentals and Applications

Despite the improvements in optical fiber manufacturing and advancements in the field in general, basic optical components such as mirrors, wavelength filters, and partial reflectors have been a challenge

[Contact Us](#)



## What is a Fiber Bragg Grating Array: Applications and

A Bragg grating, as a fiber optic sensor, has all of the benefits typically associated with these devices, such as low loss relative to fiber length, immunity

[Contact Us](#)

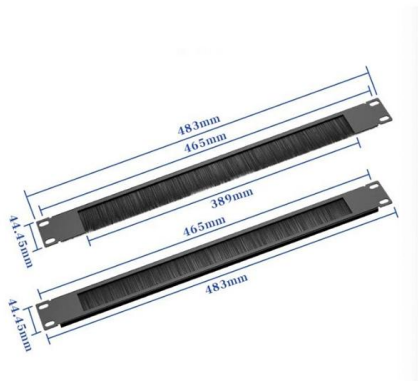

## Understanding Fibre Bragg Grating: A Comprehensive

One of their key advantages is their tunable spectral response, which can be adjusted by changing the grating period or using temperature or strain.

[Contact Us](#)

## Fiber Bragg Gratings

This is usually accomplished by treating the fiber so that it becomes photosensitive (by loading it with Hydrogen in this case) and then exposing the fiber to UV light through a grating.

[Contact Us](#)

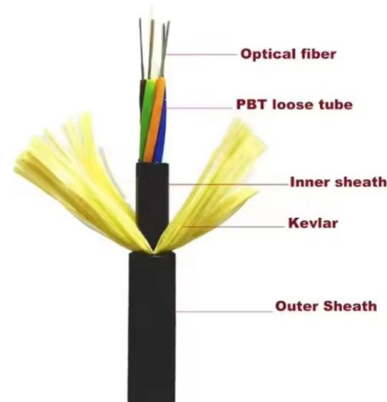

## Microsoft Word

Abstract As an important waveguiding medium, optical fiber plays significant roles in optical communications, optoelectronics, and sensors. A new type of microstructure inscribed in the optical

[Contact Us](#)



## Bragg Cell

Fiber Bragg gratings (FBGs) are permanent modulations of the index of refraction in optical fibers. An FBG with a submicrometer periodic modulation of the index of refraction functions as the filter.

[Contact Us](#)



## Fiber Bragg Gratings: The Ultimate Guide

Fiber Bragg Gratings (FBGs) are a crucial technology in the field of optics, with a wide range of applications in telecommunications, sensing, and medical fields. In this article, we will

[Contact Us](#)



## Fiber Bragg Gratings

Long-Period Gratings: These gratings have longer periods and are used for mode coupling in the same propagation direction. Applications of Fiber Bragg Gratings

[Contact Us](#)



## Fiber Bragg Gratings

Fiber Bragg Grating (FBG) technology is one of the most popular choices for optical fiber sensors for strain or temperature measurements due to their simple manufacture, as we will see later on, and

[Contact Us](#)



## Fiber Bragg grating explained

The first in-fiber Bragg grating was demonstrated by Ken Hill in 1978. Initially, the gratings were fabricated using a visible laser propagating along the fiber core. In 1989, Gerald Meltz and

[Contact Us](#)



## Fiber Bragg gratings embedded in 3D printed prototypes

In this study, we incorporated fiber optic sensors in 3D printed prototype parts. Fiber optic Bragg gratings embedded in polylactic acid were configured to measure strain and/or temperature.

[Contact Us](#)

## Fiber Bragg Gratings Information

Surface-relief Bragg gratings are etched on the cladding above the core of the D-fibers where the interaction remains within evanescent field of the supported

[Contact Us](#)



## Fiber Bragg Gratings

Despite the improvements in optical fiber manufacturing and advancements in the field in general, basic optical components such as mirrors, wavelength filters, and partial reflectors have been a challenge

[Contact Us](#)



## Contact Us

---

For datasheets, pricing, or custom fiber access solutions, please visit:  
<https://frindel.es>