

What is the service life of cable trays





Overview

Unlike conventional cable management systems, wire mesh trays are built to last, offering long-term reliability that spans decades. Understanding Cable Tray Service Life helps you plan, budget, and keep everything running smoothly. The mechanical and electrical characteristics, tests, certifications, overall quality management, recommendations mentioned in this technical guide only apply to our own cable management ranges and cannot under any circumstances be transposed to ensure, overheating or. en completely installed, without damage either to conductors or structural system use maintain spacing or to keep cables in place when the tray is ect the minimum bend ra-dius for cables as they exit the bottom of the cable tray. The lifespan of cable trays is not only related to the season and the materials used but also significantly influenced by daily maintenance and upkeep.



What is the service life of cable trays

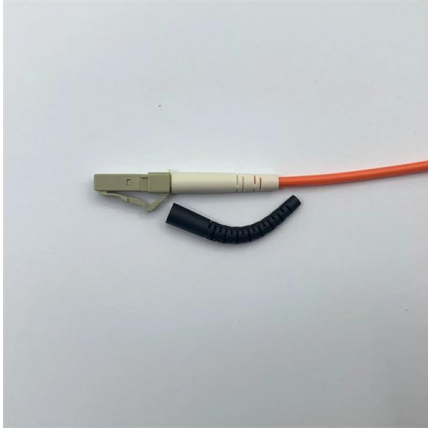

Cable Tray Technical Guide A practical guide to product selection and

Cable Tray Technical Guide A practical guide to product selection and installation This guide for engineers and installers has been developed by ABB as a practical reference regarding cable tray

[Contact Us](#)

Cable Tray Maintenance Best Practices for Longevity

In this blog, we will delve into essential cable tray maintenance practices that can help you extend the lifespan of your cable tray systems, reduce downtime, and enhance safety.

[Contact Us](#)



What Is A Cable Tray? 5 Types Of Cable Trays

A cable tray is a structural system used to support and manage electrical cables in various settings, such as industrial, commercial, and residential environments.

[Contact Us](#)

Cable Trays Selection Guide: Types, Features,

Cable trays are components of support systems for power and communications cables and wires. A cable tray system supports and protects both power and



Cable Tray Maintenance Best Practices for Longevity

Discover essential cable tray maintenance tips from Hutaib Electricals, India's leading cable tray manufacturer. Learn how to extend system

[Contact Us](#)



Everything You Need to Know About Cable Trays , Cable Trays

Discover the different types of cable trays, their many benefits when used in electrical wiring and network cabling, installation processes, and essential maintenance tips for keeping your

[Contact Us](#)



What are Cable Trays & Different Types of Cable Trays

These cable trays feature a perforated bottom and the flat area is used to support the cables placed inside the tray. These trays are most

[Contact Us](#)





Cable Tray Systems

Cable trays offer continuous support of cables, are lightweight, quick and straight forward to install just about anywhere, and generally mean that changing cabling services over the lifetime of a project is

[Contact Us](#)

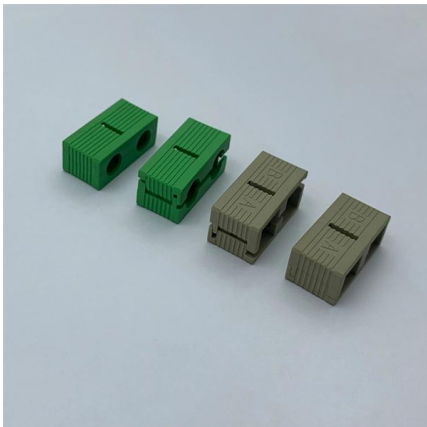

How many years is the general warranty period for cable trays?

Summarize When choosing a cable tray, in addition to considering its warranty period, you should also consider its materials, operating environment, and maintenance requirements. Usually, the warranty

[Contact Us](#)

Wire Mesh Cable Tray Price List

Discover wire mesh cable tray price list with CE-certified steel trays, 10-year guarantee, free samples, and corrosion-resistant finishes for industrial projects.

[Contact Us](#)



Types of Cable Trays: Benefits and Uses

Different types of cable trays offer key benefits, optimizing cable management and enhancing efficiency in electrical systems.

[Contact Us](#)



ASTM E1725 Fire Test for Cable Tray Systems

ASTM E1725 fire resistance testing for electrical cable systems installed in cable trays. Evaluate circuit integrity under fire exposure for life safety, industrial, and commercial critical power and control cable

[Contact Us](#)



Maintenance and Upkeep of Cable Trays

The lifespan of cable trays is not only related to the season and the materials used but also significantly influenced by daily maintenance and upkeep. The following

[Contact Us](#)

Cable Tray Systems: Requirements and Best Practices

Comprehensive guide to cable tray systems requirements: tray types, materials, loading, supports, bonding, routing, and best practices for safe electrical cable management.

[Contact Us](#)



Decades of Reliability: The Lifespan of Wire Mesh Cable

Whether in industrial, commercial, or data center applications, wire mesh cable trays continue to provide decades of reliable service, proving their

[Contact Us](#)

GUIDE CABLE TRAYS TECHNICAL



In accordance with its continuous improvement policy, Legrand reserves the right to change the specifications and illustrations without notice. All illustrations, descriptions and technical information

[Contact Us](#)



Why do cable trays age? How should we handle it?

What are the reasons for the aging of cable trays during use? What should we do to prevent the aging of cable trays?

[Contact Us](#)

Cable Tray SHIB NAL

Cable trays are not raceways, but they are treated as a structural component of a facility's electrical system. Cable trays are a part of a planned cable management system to support, route, protect and

[Contact Us](#)



Cable Tray Service Life Explained: How Long Do They Last?

Understand cable tray service life. Learn factors affecting durability, how to assess lifespan, and typical lifespans for metal, non-metal, and composite trays.

[Contact Us](#)



Cable Tray Questions , Cable Tray Institute

Answer: No. Cable trays are a support system for electrical cables, power, signal, and communication and optical fiber cables. NEC section 300-8 does not permit any tube, pipe, or equal for water, air

[Contact Us](#)

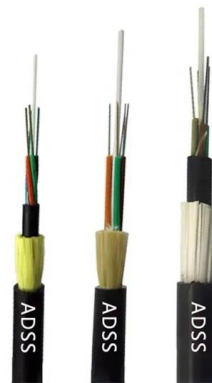

What are Cable Trays? Everything you need to know

Discover everything about cable trays in industrial settings: types, benefits, installation tips, and compliance with NEC and fire resistance standards.

[Contact Us](#)

Why do cable trays age? How should we handle it?

How to deal with the aging of cable tray suppliers? We can use hot-dip galvanizing process. Zinc has excellent corrosion resistance, and the

[Contact Us](#)

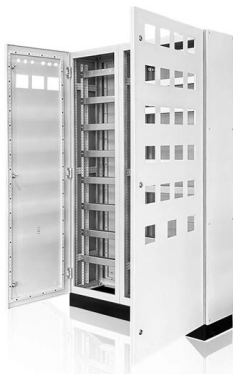
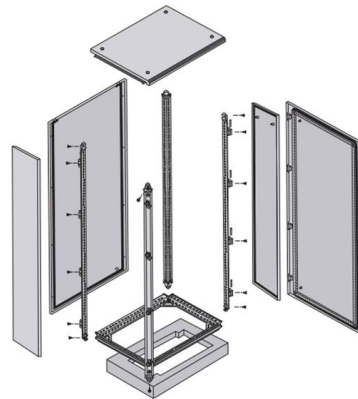

Ventilation in cable trays extends the service life of cable

Ventilation of cable trays is a critical factor in ensuring the service life and optimum performance of cables, especially in installations located in extreme

[Contact Us](#)

Decades of Reliability: The Lifespan of Wire Mesh Cable



Wire mesh cable trays are designed to withstand these challenges, maintaining structural integrity even in the most demanding settings. Their open

[Contact Us](#)



Contact Us

For datasheets, pricing, or custom fiber access solutions, please visit:
<https://frindel.es>