

Waterproof recessed door distribution box





Waterproof recessed door distribution box



SHK Outdoor MCB RCCB Waterproof Distribution Box

PRODUCT FEATURES It is applicable for special waterproof, dustproof and corrosion-proof locations Executive standard: IEC60529, EN 60309, IP65

[Contact Us](#)

Distribution Board for Sale, Outdoor DB Box, Distribution

Discover the OOHMAGE Electrical Distribution Box, a waterproof IP65 distribution board designed for safety and durability. Ideal for homes, offices, and factories.

[Contact Us](#)



Sieno IP66 Class Waterproof Metal Distribution Boxes

Sieno-IP66-Waterproof-Metal-Distribution-Boxes Designed to enclose electrical and or electronic equipment and protect against harsh, industrial environments. For use as instrument enclosures,

[Contact Us](#)

IP65 ABS Distribution Protection Box, 12 Way Waterproof Circuit

IP65 ABS Distribution Protection Box, 12 Way Waterproof Circuit Breaker Distribution Box 12 DIN Rail Outdoor Distribution Junction Box for Indoor Outdoor Wall Circuit Breaker (255 x 200 x 110mm) -

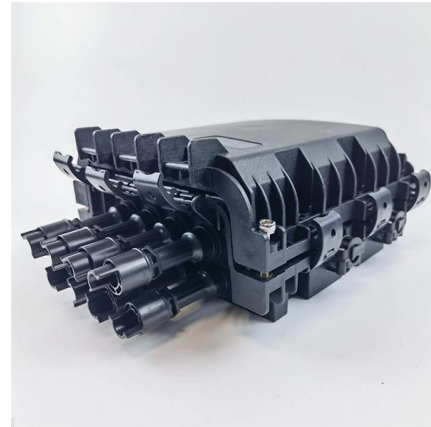

Waterproof distribution boxes , ELMARK

Waterproof distribution boxes Home Distribution Boards and Boxes Plastic distribution boxes Waterproof distribution boxes Back Sort by: Name Items per page:

[Contact Us](#)



Xiciki 3-Way DIN Rail Enclosure Box, Weatherproof Distribution Box

This electrical enclosure is perfect for organizing DIN rail distribution box circuits efficiently and securely. ?Safety & Security?: The electrical enclosure provides safe housing for all your electrical

[Contact Us](#)



Waterproof Box

Whether you need a waterproof distribution box, an aluminium waterproof box, a plastic waterproof box or a fibreglass box, saipwell can provide them all,

[Contact Us](#)





Outdoor Distribution Box IP55

Outdoor distribution box IP55 - Reliable waterproof Junction Boxes for electrical wiring. Durable, customized designs for various applications. Shop now!

[Contact Us](#)



Electrical Enclosures , Electrical Cabinets , Toolstation

These include waterproof electrical boxes, weatherproof enclosures and junction boxes. Alongside our range of electrical enclosures, we also have an extensive selection of waterproof and weatherproof

[Contact Us](#)

EKDB10 IP65 Waterproof Distribution Box , Industrial

EKHA Series Waterproof Distribution Box is designed for demanding electrical applications that require reliable waterproof, dustproof, and anti-corrosion protection.

[Contact Us](#)



EKDB10 Distribution Box , IP65 Plastic Waterpro

EKDB10 Distribution Box , IP65 Plastic Waterpro Discover EKDB10 IP65 waterproof distribution boxes made of durable PC plastic. Available in 4-39 ways,

[Contact Us](#)



Waterproof Distribution Box , IP65 & IP66 Rated

ZCEBOX manufactures IP65 & IP66 waterproof distribution boxes for outdoor and industrial applications. Built with durable materials, CE & ROHS certified. Contact

[Contact Us](#)



GDB Waterproof Circuit Breaker Distribution Box

PRODUCT FEATURES It is applicable for special waterproof, dustproof and corrosion-proof locations Executive standard: IEC60529, EN 60309, IP65

[Contact Us](#)

orion+ waterproof enclosures and cabinets , Hager

The orion+ waterproof enclosures and cabinets, rated IP65 or IP66, made of metal or polyester, are designed for general use and are suitable for the most extreme conditions (chemical aggressiveness,

[Contact Us](#)

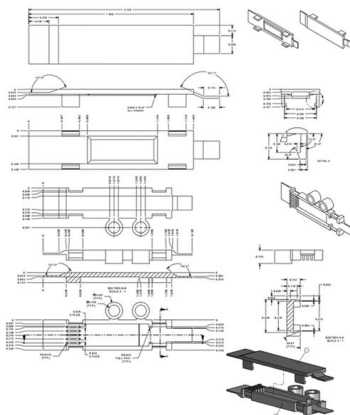
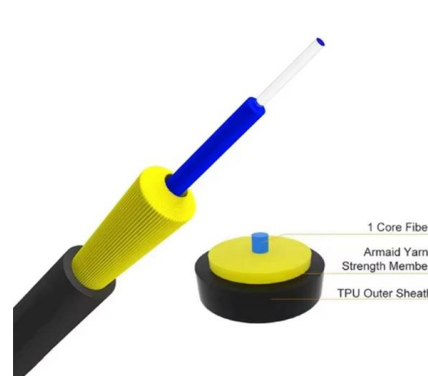

EKDB10 Distribution Box , IP65 Plastic Waterproof

Discover EKDB10 IP65 waterproof distribution boxes made of durable PC plastic. Available in 4-39 ways, single/double/triple layers, ideal for industrial, commercial,

[Contact Us](#)



IP65 Distribution Box

IP represents the international protection level (Ingress Protection), 65 means dustproof level 6 and waterproof level 5. This grade of distribution box is highly

[Contact Us](#)



2-Way Distribution Protection Box, IP66 Waterproof

About this item Transparent Cover: This 2-way electric panel DIN distribution box provides safety protection for your wall circuit, the surface is a transparent gray

[Contact Us](#)

Waterproof Distribution Box WPN , IP65 Clear Door DIN

The WPN Waterproof Distribution Box is a surface-mount enclosure using a rigid ABS body with a smoked PC transparent door. It ships with a DIN rail for

[Contact Us](#)

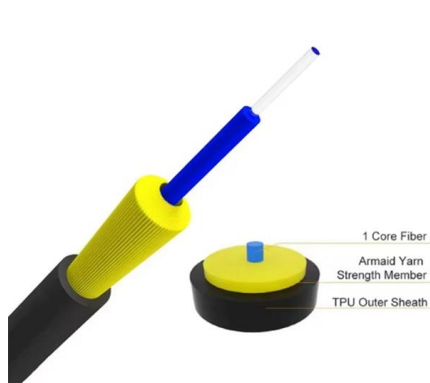
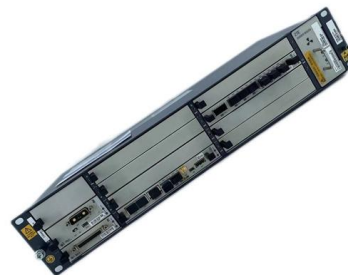

HA Series IP65 Waterproof Power Distribution Box

HA Series Waterproof Power Distribution Box Product Highlight: Outstanding Waterproof Performance (IP65 Rating):The fully sealed enclosure delivers

[Contact Us](#)



HA Series IP65 Waterproof Power Distribution Box

Crafted with advanced materials and innovative structures, it delivers reliable and stable performance in harsh environments, including humid, dusty, or outdoor

[Contact Us](#)



Waterproof Distribution Box

Waterproof distribution box for outdoor use, strong sealing to protect from water, dust, impacts. Options for sizes, fast quotes.

[Contact Us](#)

GDB Waterproof Circuit Breaker Distribution Box

PRODUCT FEATURES It is applicable for special waterproof, dustproof and corrosion-proof locations Executive standard: IEC60529, EN 60309, IP65 TECHNICAL DATA

[Contact Us](#)



SHT Clear Cover Surface Waterproof Circuit Breaker

SHT Clear Cover Surface Waterproof Circuit Breaker Distribution Box Series: SHT Material: ABS IP Rating: IP65 NEMA Rating: 4X Color: Light Grey Application: Outdoor

[Contact Us](#)

RCB Plastic Distribution Box



In addition, the IP67 plastic street light waterproof box is composed of ABS shell and PC door, which has excellent heat resistance and halogen-free and silicon-free characteristics, providing a reliable and

[Contact Us](#)



Waterproof Electrical Distribution Box, SHPN Series

The Waterproof Electrical Distribution Box, with its high-definition transparent cover, is a transparent panel that not only allows for easy monitoring of the internal

[Contact Us](#)



Waterproof distribution boxes , ELMARK

Waterproof distribution boxes - large product range in ELMARK.

[Contact Us](#)



Contact Us

For datasheets, pricing, or custom fiber access solutions, please visit:
<https://frindel.es>