

# The function of each layer of optical cable





## Overview

---

Optical fiber consists of a core and a cladding layer, selected for due to the difference in the refractive index between the two. This coating protects the fiber from damage but does not contribute to its properties. What is the purpose of each layer of fiber optic cables?

· Introduction to Fiber Optic Technology · Defining Fiber Optic Cables: An Overview · The Core: The Light Transmission Pathway · The Cladding: Refractive Properties and Light Containment · Strength Members: Ensuring Durability and Longevity · . A fiber-optic cable, also known as an optical-fiber cable, is an assembly similar to an electrical cable but containing one or more optical fibers that are used to carry light. The first low-loss optical fiber was created in 1970 by Robert Maurer, Donald Keck, and Peter Schultz at Corning Glass Works (now Corning Incorporated). This innovation made it possible to send light messages effectively over large distances.



## The function of each layer of optical cable

---



### The Four Basic Components of a Fiber Optic Cable

Each layer performs a specialized function, ensuring the light-carrying medium remains protected and signal integrity is maintained. The journey of light inside a fiber optic cable begins

[Contact Us](#)

### How optical communication cables work and how they

In several articles, I mentioned optical fibre in the context of substation automation, protection signaling, communication between electrical

[Contact Us](#)



### Fiber optic cable types, works, and functions

This tutorial explains fiber optic cable types, characteristics, and functions. Learn how a fiber optic cable works and differences between SMF and

[Contact Us](#)

### What is the purpose of each layer of fiber optic cables?

Typically, a fiber optic cable contains three basic components: the core, which carries the light signals; the cladding, which surrounds the core with a lower refractive index and contains the light; and the



### Three Basic Components of a Fiber Optic Cable

Typically, a fiber optic cable contains three basic components: the core, which carries the light signals; the cladding, which surrounds the core with a

[Contact Us](#)

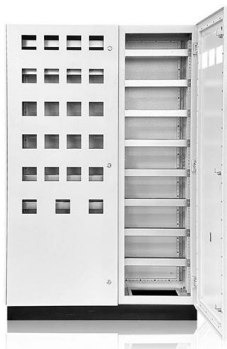

### THE BASICS OF FIBER OPTIC CABLE a Tutorial

While fiber optic cable itself is cheaper than an equivalent length of copper cable, fiber optic cable connectors and the equipment needed to install them are more

[Contact Us](#)



### Basic Components of a Fiber Optic Cable - trueCABLE

This article examines the key components that make up a fiber optic cable including the core, cladding, coating, strengthening fibers and cable jacket.

[Contact Us](#)





## fiber optic cable layers

B. Importance of fiber optic cables in modern communication C. Overview of the article's structure II. Inner Layers of a Fiber Optic Cable A. Core layer 1. Definition and function 2. Materials used in the

[Contact Us](#)



## Fiber Optics: Understanding the Basics

o Electrical Isolation -- Fiber optics do not need a grounding connection. Both the transmitter and the receiver are isolated from each other and are therefore free of

[Contact Us](#)



Fast shipment in stock Default white and black, contact customer service for notes

4U standard model



## What is a Fiber Optic Cable, How Are They Constructed?

Fiber Optic cable employs photons for the transmission of digital signals. A fiber optic cable consists of a strand of pure glass a little larger than a human hair. Photons

[Contact Us](#)



IP65/IP55 OUTDOOR CABINET

OUTDOOR CABINET WITH AIR CONDITIONER

OUTDOOR ENERGY STORAGE CABINET

19 INCH

## Understanding the Components of Optical Fiber Cables:

By familiarizing yourself with the core, cladding, buffer coating, strength member, and protective outer jacket, you can find the ideal optical fiber cable solution for your

[Contact Us](#)



## The 3 Main Components of Fiber Optic Cables

What are the components of fiber optic cables? Learn about each important layer and how each one contributes to excellent cable performance.

[Contact Us](#)



## Fiber Optic Cable Components: Full List & Explain

Delve into the components of fiber optic cables, including fiber strands, cladding, coating, strength members, and connectors. Learn how these elements contribute to reliable data transmission and

[Contact Us](#)

## Fiber Optics and Types

Fiber optics are generally used for high-speed internet, telecommunications, medical devices, and many more industrial applications.

[Contact Us](#)

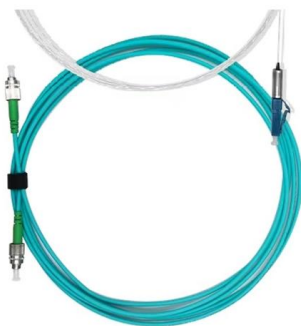

## Optical Fibre Cable

Depending on the amount of power needed and the distance needed, the fibers are designed to allow light to travel in parallel with the optical fiber. While multimode fiber is used for

[Contact Us](#)



## What Are the 3 Main Layers of Fiber Optic Cabling?

Fiber optic cables are made of three parts: the core, cladding, and coating. The core carries light to send data, while the cladding keeps it on track.

[Contact Us](#)



## The Anatomy of a Fiber Optic Cable , ADD

The cable jacket is the outer layer of the fiber optic cable and serves to protect the cable from environmental hazards. How Does Fiber Internet Work? Picture a

[Contact Us](#)

## The Essential Guide to Fiber Optic Cable Core:

Discover the vital role of the fiber optic cable core in transmitting light signals. This essential guide covers functionality, types, and applications of

[Contact Us](#)



## Optical Fibre Cable

Greater carrying capacity--Optical fibers may be grouped into cables of a given diameter since they are significantly thinner than copper wires. This enables extra phone lines to use the same

[Contact Us](#)



## Fiber Optic Cables: Definition, How It Works, and Its

Functions of Optical Fiber Fiber optic cables serve various functions across multiple industries, including: Telecommunications: The primary function

[Contact Us](#)



## Optical Fiber Structure

Fiber-optic chemical sensors require strong interaction between the sensing layer and the evanescent wave field to enhance the sensor performance. This can be achieved by modifying the optical fiber

[Contact Us](#)

## What is the purpose of each layer of fiber optic cables?

The chief purpose of the physical layer is to define the functional specifications for links between end systems and the electrical, optical and radio signals that carry data. Reliability, path selection and

[Contact Us](#)

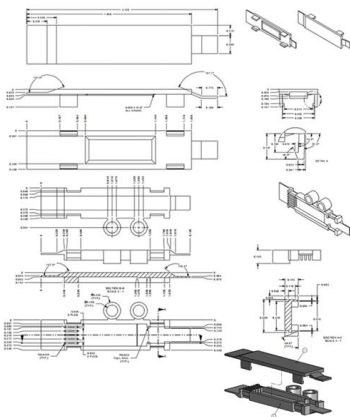
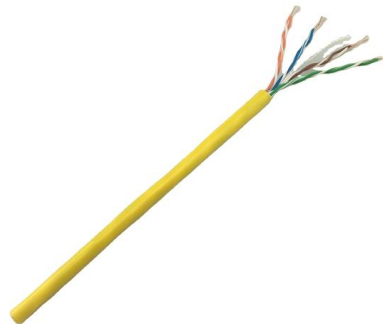

## Fiber Optic Cable Components & Materials: Complete

Explore the 5 key fiber optic cable components and materials used in modern networks. Learn how glass, coatings, and strength members affect

[Contact Us](#)



## What is the purpose of each layer of fiber optic cables?

Fiber optic cables are marvels of modern engineering that rely on the sophisticated integration of multiple layers. Each layer serves a unique and vital purpose, ensuring that the data

[Contact Us](#)



## An Overview Of Optical Fiber Cable Structure And Components

A fiber cable contains up to hundreds of incredibly thin glass fiber cores within protective layers. Surrounding layers cushion from crushing

[Contact Us](#)

## The Four Basic Components of a Fiber Optic Cable

Each layer performs a specialized function, ensuring the light-carrying medium remains protected and signal integrity is maintained. The Core Mechanism for Light Transmission The

[Contact Us](#)



## Basics of Fiber Optics

II.2 Optical Fiber/Cable In this section, we discuss the structure and properties of an optical fiber, how it guides light, and how it is cabled for protection. An optical fiber is made of 3 concentric layers (see

[Contact Us](#)



## Contact Us

---

For datasheets, pricing, or custom fiber access solutions, please visit:  
<https://frindel.es>