

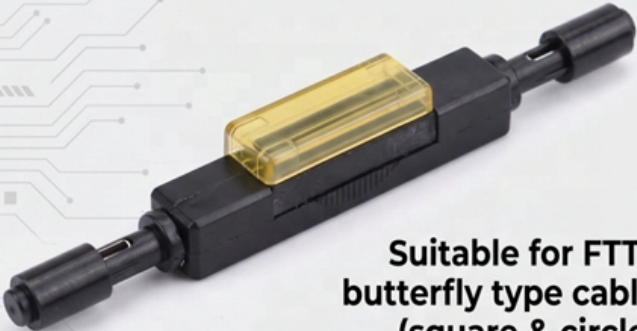



Standards for direct-buried optical cable lightning protection wires

HIGH-PERFORMANCE FIBER OPTIC MECHANICAL SPLICE



Suitable for FTTx butterfly type cable (square & circle)

APPLICATIONS:

-  Patch panels
-  Distribution frames
-  FTTH Outlets
-  LAN environments

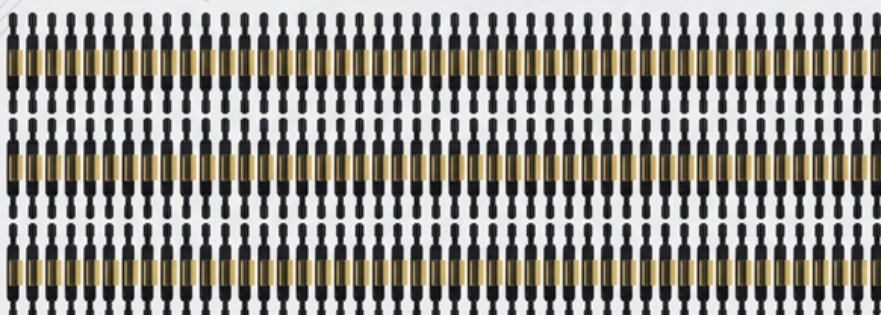



Overview

101 describes characteristics, construction and test methods of optical fibre cables for buried application. The Lightning Protection Institute is a nationwide not-for-profit organization founded in 1955 to promote lightning protection education, awareness, and safety. The lightning protection industry began in the United States when Benjamin Franklin postulated that lightning was electricity, and a metal. Jump directly to This guide is intended to assist code authorities, installers and contractors in determining the suitability of UL Certified, Listed. A buried cable is an electrical wire or cable installed below ground level, typically encased in protective sheathing or conduit to safeguard it from environmental and physical damage.



Standards for direct-buried optical cable lightning protection wires

50KW modular power converter



Direct Buried Fiber Optic Cables , Optical

Loose tube fiber optic cables are high-density, lightweight, and durable for easy handling and installations. They contain buffer tubes with either 12 or 24 single

[Contact Us](#)

Buried Cables: What are the Regulations for Buried

Learn about buried cable regulations, including the required burial depths in different locations and protective safety measures for underground cable.

[Contact Us](#)



How Deep to Bury Fiber Optic Cable: A Best Practice

Ongoing Protection Post-Installation While proper cable specification, effective burial techniques, and meeting depth targets promote long-term

[Contact Us](#)

Recommendation ITU-T L.101 (08/2024)

Recommended technical requirements are detailed by reference to IEC 60794-3-11 on outdoor optical fibre cables for duct, directly buried, and lashed aerial applications. Changes and



Lightning protection guide

Just like its predecessors, this edition of the lightning protection guide offers assistance in installing professional lightning protection systems in line with the very latest standards.

[Contact Us](#)



Buried Wiring Info Sheet

The following are explanatory material for some Code requirements regarding buried electrical wiring that are applicable to most residential applications.

[Contact Us](#)

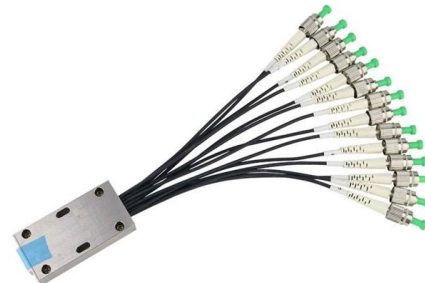

Lightning Protection and Strong Current Protection

Newly built silicon core pipes or direct buried fiber optic cables with metal components should be set up according to the soil resistivity (ρ_{10}) at a

[Contact Us](#)

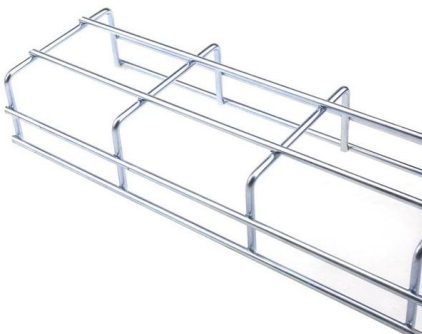



998-2012

Purpose: Direct strokes from lightning can damage substation equipment and bus work. To protect equipment, substation engineers can install direct stroke lightning shielding. This guide is

[Contact Us](#)



Protection of Buried Cable from Direct Lightning Strike

This paper presents studies of protection schemes for buried cables. A formula is introduced that gives the maximum peak lightning current for various ground resistivities. Maximum and minimum arcing

[Contact Us](#)

Lightning Protection Overview

Copper and aluminum main cable conductors for lightning protection are designed to a smooth weave or rope-lay standard using smaller gauge

[Contact Us](#)



Buried conduits and ducts

The use of unarmoured cables, such as HO7RN-F rubber flexible cables or unarmoured XLPE cables buried in the ground, is becoming more popular,

[Contact Us](#)



P998 D24-4, Jul 2024

Scope: This guide describes the general nature of lightning and discusses design methods for placement of masts and shield wires to provide direct stroke shielding of outdoor substations. Tables,

[Contact Us](#)



Direct Buried Cable Specification , PDF , Dispersion

Standard Direct Buried Cable - Free download as PDF File (.pdf), Text File (.txt) or read online for free. This 3-page document is a specification sheet from Lite

[Contact Us](#)

Cable and grounding requirements in lightning protection systems

Lightning protection isn't just about those dramatic lightning rods you see on rooftops - it's a sophisticated system where cables and grounding play starring roles.

[Contact Us](#)



GENERAL INFORMATION

All direct burial cable should contain a corrugated steel armor tape for protection against rough terrain and rodents. Before digging, all existing underground utilities such as buried cables, pipes, and other

[Contact Us](#)

Direct-buried Installation of Fiber Optic



Additional Cable Protection 2.16. In certain installation areas, for example, in frozen ground, rights-of-way with limited access (public highways, private property boundaries), it may be more efficient to

[Contact Us](#)



How to Build Lightning Protection System for Fiber Optic Cables?

The intermediate grounding solutions are mainly designed for direct burial fiber cables and aerial fiber cables. Direct burial fiber cables are laid with lightning protection wires according to

[Contact Us](#)

ITU-T Rec. K.47 (05/2012) Protection of telecommunication lines

Protection of telecommunication lines against direct lightning flashes Summary Recommendation ITU-T K.47 gives a procedure in order to protect telecommunication lines using metallic components

[Contact Us](#)

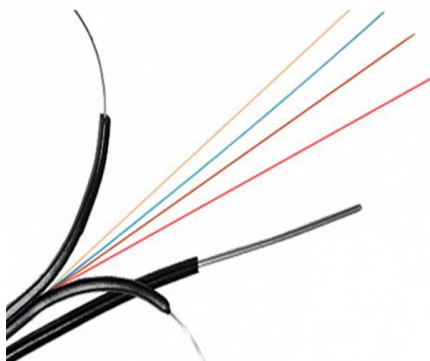

Direct-buried cable

Direct-buried cable (DBC) is a kind of communications or transmissions electrical cable which is specially designed to be buried under the ground without any other

[Contact Us](#)



Buried Cable Installation

Individual company practices for placing fiber optic cable should supersede any conflicting instructions in this document when they do not exceed the cable's optical and mechanical performance

[Contact Us](#)



Direct Buried Cable Specification , PDF , Dispersion

This 3-page document is a specification sheet from Lite Kabel Sdn. Bhd. for single mode optical fibre cables with loose fibres in stranded tubes and corrugated steel

[Contact Us](#)

Underground Wires and Cables Entering Buildings , UpCodes

Direct-buried cables must be installed with a minimum depth of 150 mm (6 inches) of cover. This requirement ensures proper protection and safety for the cables as they enter buildings.

[Contact Us](#)



LPI-175 / 2023 Edition

Copper and aluminum main cable conductors for lightning protection are designed to a smooth weave or rope-lay standard using smaller gauge individual wires. This construction allows a maximum surface

[Contact Us](#)



How to Build Lightning Protection System for Fiber Optic Cables?

Direct burial fiber cables are laid with lightning protection wires according to the soil resistivity, and the aerial fiber cables are grounded with grounding poles and suspension wires.

[Contact Us](#)

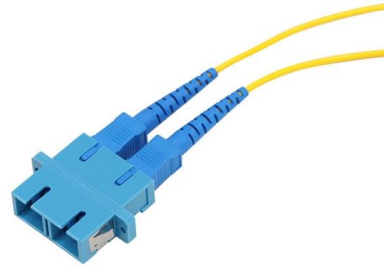

What Is Direct Burial Wire and What to Consider When

Can you put direct burial wire in conduit? In some cases, conduit may not be required for direct buried wires, but if additional protection is needed, the

[Contact Us](#)

Contact Us

For datasheets, pricing, or custom fiber access solutions, please visit:
<https://frindel.es>