

# **Smart Overseas Warehouse for Cybersecurity Equipment**

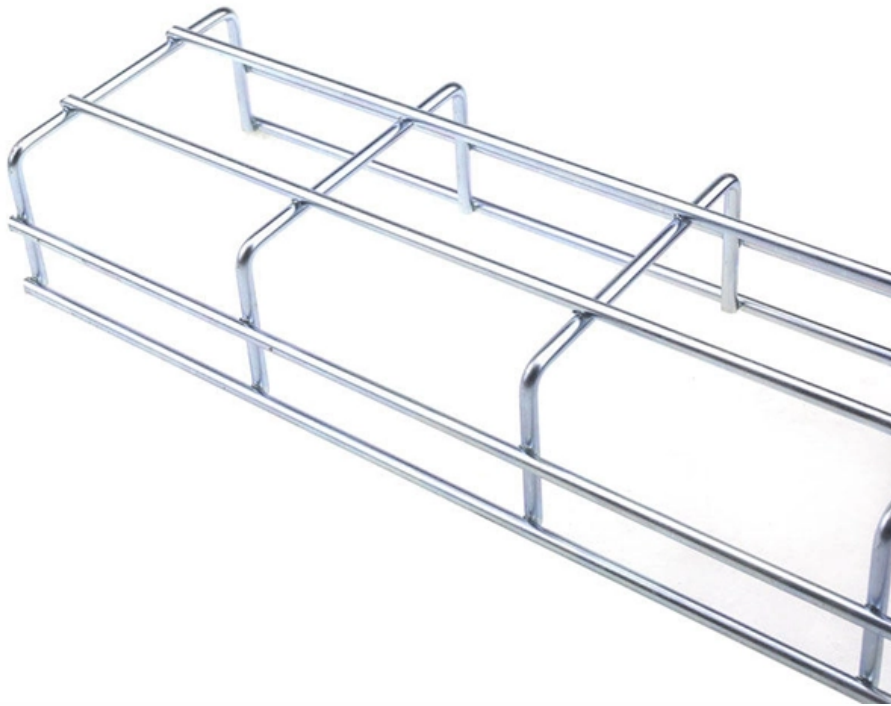



## Smart Overseas Warehouse for Cybersecurity Equipment

---

### Smart Warehousing Technologies: A Comprehensive

Explore smart warehousing technologies and strategies industry leaders are using to stay competitive in an evolving logistics landscape.

[Contact Us](#)



### Leveraging High-Security Warehousing for Sensitive Cybersecurity

This article delves into strategic approaches for leveraging high-security warehousing solutions to ensure the integrity and security of cybersecurity hardware throughout the supply chain.

[Contact Us](#)



### Sorting out cybersecurity for modern warehouse logistics

Staying secure As well as its expertise providing cybersecurity for legacy equipment or new projects - Prime Vision holds itself to high security standards and continually innovates to keep pace with the

[Contact Us](#)

### 6 Warehouse Security Measures: A Complete Guide

Learn how to implement effective warehouse security measures with our guide. From access control and surveillance to audits -- we cover it all.

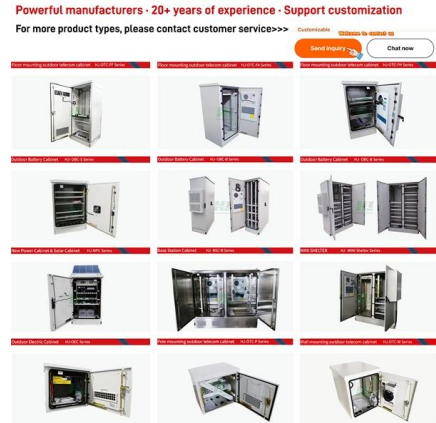

### Warehouse IT Security in 2025: MSP Solutions for Cyber Threats

This article explains how warehouses are exposed to cyber threats in 2025 and how Managed Service Providers (MSPs) help protect them. You'll learn about the main risks, what makes warehouse

[Contact Us](#)

### Study Report on Smart Security Devices (SSDs)

With the growing integration of Internet of Things (IoT) technologies, SSDs are setting a new standard for container security. This study report highlights the benefits, challenges, and

[Contact Us](#)

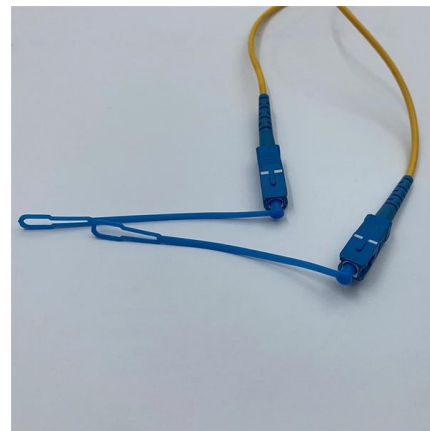

### How smart warehouses are exposing new cybersecurity

According to Deloitte, nearly 79% of leading supply chain companies have invested in smart warehouse technologies in the last three years. Yet as

[Contact Us](#)





## Cyber Security in Smart Warehousing: Protecting the Digital Supply

At NCG, we understand that secure connectivity is the backbone of any smart warehouse. Our technology solutions are built to support robust cybersecurity, from secure network infrastructure

[Contact Us](#)



## Smart Warehouse: Definition, Benefits, and

A smart warehouse represents the next stage of evolution in warehouse management, where cutting-edge technologies such as

[Contact Us](#)

## Enhancing Warehouse Cybersecurity

Learn best practices enhancing warehouse cybersecurity to secure your WMS, and data with 8Stock. Protect your warehouse from cyber threats with

[Contact Us](#)

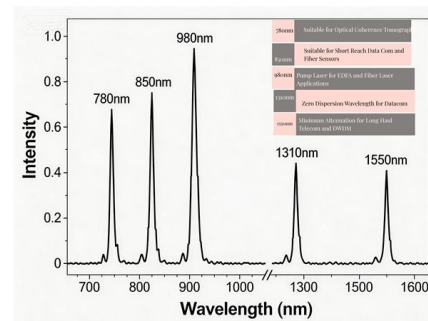

## Protecting the Digital Backbone of Modern Logistics

Warehouse Cybersecurity As modern warehouses increasingly rely on digital infrastructure and interconnected systems, cybersecurity has become a critical pillar of operational

[Contact Us](#)



## The importance of Cybersecurity in warehouses

Cybersecurity in warehouses has evolved from a secondary concern to a fundamental priority in supply chain management. In an increasingly digital

[Contact Us](#)

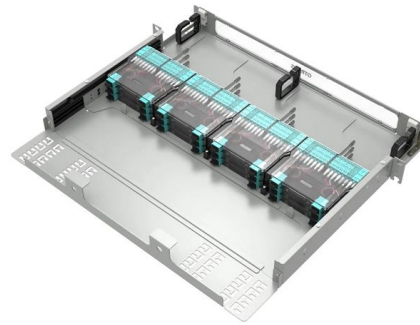

## Smart Warehouse Solutions , A Complete Guide

What Is a Smart Warehouse? A smart warehouse is a technology-driven facility that uses automation, data analytics, and integrated systems to

[Contact Us](#)

## Smart Warehouses of the Future

If there was ever a time to embrace smart warehouses that utilize robots and automated processes, it is now: labor shortages, social distancing measures, and

[Contact Us](#)



## Cybersecurity for Warehouses Cybersecurity for Smart Warehouse

In the evolving landscape of warehouse leasing, cybersecurity for smart warehouses emerges as a pivotal concern. Smart warehouses, with their reliance on Internet of Things (IoT) devices,

[Contact Us](#)



## Exploring Advanced Technologies in Overseas Warehousing

Overseas warehouse services in 2025 leverage AI, IoT, and automation to enhance efficiency, sustainability, and real-time inventory management globally.

[Contact Us](#)



## Cybersecurity in Logistics and Warehouse Management

By addressing the cybersecurity skills gap, logistics and warehouse management companies can enhance their resilience against cyber threats and ensure that

[Contact Us](#)

## Leveraging Innovative Technologies and Risk Management Strategies

This paper presents a comprehensive approach that includes technological innovations, regulatory frameworks, and a transition towards sustainable practices in warehouse operations. It

[Contact Us](#)



## AI in Smart Ports and Warehouses Balancing Efficiency and Security

The integration of AI and IoT devices in smart ports and warehouses significantly expands the potential attack surface for cybercriminals. Each connected device represents a potential entry

[Contact Us](#)

## Warehouses, Robotics and Cyber Security -



## What You

Warehouses store vast amounts of sensitive data, including customer information, inventory records, and financial transactions, making them attractive

[Contact Us](#)



## How smart warehouses are exposing new cybersecurity

In today's logistics landscape, smart warehouses are reshaping how goods are stored, picked, and shipped. Advanced automation, IoT-enabled

[Contact Us](#)

## Smart Warehousing 101: Systems & Best Practices

Share proven best practices for running smart warehouses efficiently. Introduce Modula's smart warehouse systems, which automate storage and scale

[Contact Us](#)



## Cybersecurity in Logistics and Warehouse Management

Cybersecurity in Logistics and Warehouse Management 2025 The logistics and warehouse management industry has undergone a significant transformation,

[Contact Us](#)





## Cybersecurity for Warehouses Cybersecurity for Smart Warehouse

Secure your smart warehouse with our comprehensive cybersecurity solutions, reducing threats and enhancing efficiency.

[Contact Us](#)



## How to Build a Comprehensive Cybersecurity Strategy

A good cybersecurity plan uses many layers to keep warehouse management systems safe from both real-world and online dangers. This kind of

[Contact Us](#)



## Protecting the Digital Backbone of Modern Logistics

Poorly secured IoT devices--such as sensors and smart shelves--can serve as entry points for cybercriminals, providing backdoor access to the broader warehouse network.

[Contact Us](#)



## How Smart Warehouses Are Redefining Logistics in

Discover how smart warehouses across Asia are transforming logistics through automation, AI, IoT, and sustainability. Learn how companies like JD

[Contact Us](#)





## Cybersecurity: The First Line of Defense for Your Warehouse

The rise in cyber threats such as ransomware and phishing attacks underscores the imperative need for robust cybersecurity measures.

[Contact Us](#)

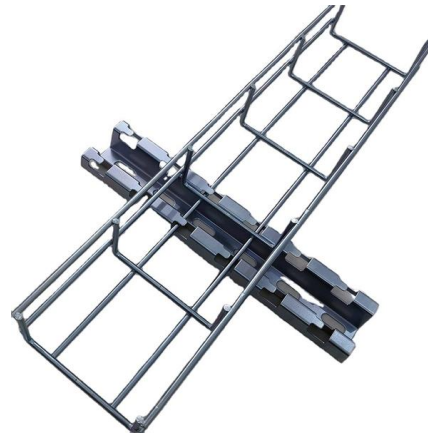

## Warehouse Security Systems: Essential Guide

Discover top strategies and technologies for warehouse security systems to protect your assets and streamline operations with our comprehensive

[Contact Us](#)

## Contact Us

---

For datasheets, pricing, or custom fiber access solutions, please visit:  
<https://frindel.es>