

Recommended Upgraded Distribution Boxes





Recommended Upgraded Distribution Boxes

Length:14.5mm
Small-end inner diameter:2.0mm
Large-end inner diameter:3.5mm
Outer diameter:5.2mm



Complete Guide For Distribution Boxes Types

The correct choice and installation of distribution boxes are crucial for electrical safety, efficiency, and reliability. This guide provides an exhaustive overview of

[Contact Us](#)

Ultimate Guide To Distribution Boxes Db Boxes Types

This ultimate guide explains what a distribution box does, its internal components, common types, real-world applications, and how to select the right DB Box for

[Contact Us](#)



Electrical Distribution Board Upgrade - Jarlam Electrics

Does your business need an Electrical Distribution Board (EDB) upgrade? Jarlam Electrics specialises in this area and can expertly guide you through the process. What Are Electrical Distribution Boards?

[Contact Us](#)

How to choose high-quality industrial distribution boxes

In the industrial production process, distribution boxes are crucial equipment. In order to ensure the smooth progress of the production process and



Distribution Board Upgrades - Cost, How Often?, Types

Read on to find out what a distribution board is, its different types, why you need to upgrade it and how often.

[Contact Us](#)



The Complete Guide to Distribution Box: Installation, Types & More

Different applications require different types of distribution boxes. Selecting the right type ensures optimal performance and compliance with relevant standards. Home distribution boxes

[Contact Us](#)



Customizing distribution boxes based on customer

When selecting and customizing distribution boxes, it is recommended to consult professionals or suppliers who can provide more accurate suggestions

[Contact Us](#)





Best distribution boxes in 2025: Which one should you choose?

If you're scratching your head over which distribution box to pick for your home or project this year, you're not alone. These unsung heroes of your electrical setup are like the nerve center of

[Contact Us](#)

02

High Quality Material



High hardness to resist external impact, Good Shaping Performance, Good Look and Anti-rust



Understanding Distribution Boxes: Your Guide to Power

Weatherproof Distribution Boxes These serve specific outdoor purposes, with rain, dust, and extreme temperatures sealed shut, protecting any

[Contact Us](#)

Distribution Boxes Types - The Complete Guide

The power distribution boxes deliver electricity from the main electrical main to other circuits. Several distribution boxes are designed for specific use in

[Contact Us](#)

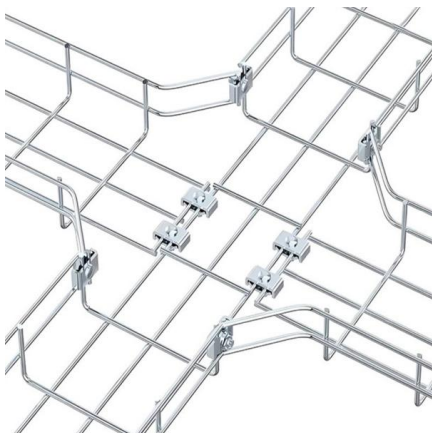

Distribution Boxes Types - The Complete Guide

A commonly used distribution box contains doorbells, earth leakage devices, timers, or contact breakers. However, the distribution boxes have

[Contact Us](#)



How to choose a distribution box of the right size for a project based

If you're like most electrical professionals, picking the right distribution box for your project can feel like navigating a maze. I've been in those shoes - staring at spec sheets, worrying about

[Contact Us](#)



How to Choose a House Distribution Box , CHINT global

A well-chosen distribution box ensures the safety and efficiency of your household electrical system. This article guides you through selecting a

[Contact Us](#)

The Complete Guide to Distribution Box: Installation, Types & More

Blog The Complete Guide to Distribution Box: Installation, Types & More By Admin Aug 2, 2025
No Comments # distribution box Introduction
Electrical systems power our homes, offices, and

[Contact Us](#)

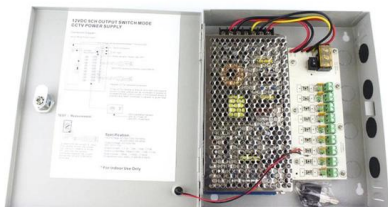

Understanding IP Protection Ratings for Distribution Boxes: Choosing

When you're setting up electrical systems, distribution boxes are like the unsung heroes that keep everything running smoothly. You probably don't give them much thought until something

[Contact Us](#)



The Importance of Distribution Boxes in Electrical Systems

Distribution boxes are an essential component of any electrical system, providing a safe and reliable way to distribute power to various circuits in

[Contact Us](#)



How to Install a Distribution Box--A Comprehensive

What is a Distribution Box? First of all, you need to have a simple understanding of the definition of a distribution box, and make it clear which kind

[Contact Us](#)

Distribution Box and Selection Guide

This guide provides information on how to select the appropriate Distribution Box for Electric project. If you have any questions about distribution

[Contact Us](#)

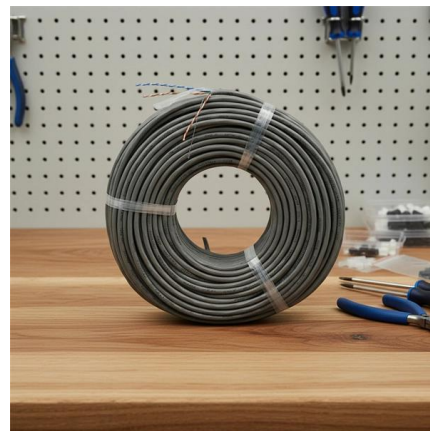

Upgrade Your Distribution Board for Safety & Efficiency

A distribution board, sometimes referred to as an electrical panel or fuse box, is a crucial component that distributes electricity from the primary power

[Contact Us](#)



Ultimate Guide To Distribution Boxes Db



Boxes Types

Introduction For procurement professionals, electrical contractors, and project managers, choosing the right Distribution Box (DB Box) is a critical decision that

[Contact Us](#)



1.An Ultimate Guide for Metal Distribution Boxes

1) Metal Distribution Boxes Constructed from steel, aluminum, or cast iron, metal distribution boxes are highly durable and resistant to mechanical damage. Ideal

[Contact Us](#)



The Ultimate Guide to Distribution Box Types

Discover the key types of distribution boxes with NUOMAK's comprehensive guide. Learn about Main Distribution Boards (MDB), Consumer Units, Transfer

[Contact Us](#)



How to Choose a Home Distribution Box - Expert Guide

Learn how to choose the right home distribution box with our expert guide. Compare circuit capacity, IP ratings, breaker types & avoid common mistakes.

[Contact Us](#)





What is the Ideal Installation Height for a Distribution Box

Install a distribution box at 4.5 to 5.5 feet high for safety, accessibility, and compliance. This height ensures easy use and protection from hazards.

[Contact Us](#)



Power Distribution Boxes Explained Simply

Discover the essentials of a Power Distribution Box--how it works, key types, benefits, and tips to ensure safe, efficient electrical power management.

[Contact Us](#)

Top 6 Distribution Box Makers with Innovative Features in 2025

See the best distribution box manufacturer picks for 2025, featuring top brands with advanced safety, smart features, and global certifications.

[Contact Us](#)



How to Choose the Right Distribution Box for Your Home or Workshop

Learn how to choose the right distribution box for your home or workshop. Discover sizing rules, component selection, and strict electrical safety standards.

[Contact Us](#)



Contact Us

For datasheets, pricing, or custom fiber access solutions, please visit:
<https://frindel.es>