

Prices of fire protection distribution boxes from New Zealand manufacturers

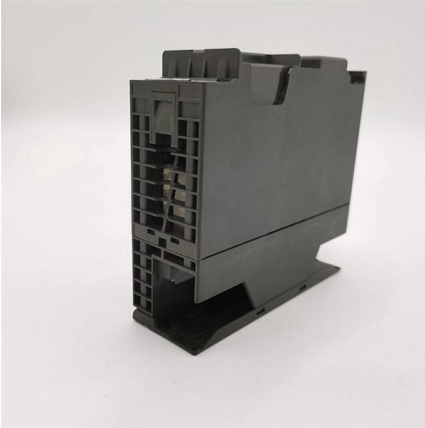



Prices of fire protection distribution boxes from New Zealand manu



Fire Protection Equipment NZ, Auckland, Wellington, Christchurch

Fire Protection Equipment NZ, Auckland, Wellington, Christchurch: Firewatch NZ is a 100% Kiwi specialist fire protection company with agents across New Zealand including Auckland, Wellington

[Contact Us](#)

Fire Fighting Equipment , Fire Protection Equipment

The threat from a fire can strike at any time, particularly in regional areas during summer. Advanced fire protection systems are a key factor in protecting your

[Contact Us](#)



Fire Extinguisher Cabinet Manufacturers , FSP New Zealand

FSP New Zealand is a leading manufacturer & supplier of fire safety cabinets. We offer superior quality fire extinguisher cabinets with UV

[Contact Us](#)

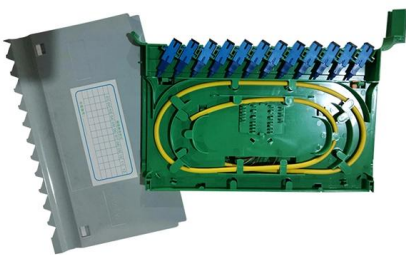

Fire Rated & Resistant Electrical Enclosures & Junction

Fire resistant enclosures and junction boxes are used to maintain electrical and electronic circuit integrity to emergency lighting, power and control cables in both



Asia's Premier News Agency

ANI brings the latest news on Politics and Current Affairs in India & around the World, Sports, Health & Fitness, Entertainment, News.

[Contact Us](#)

Fire Safety NZ , Fire Compliance , Fire Safety Information

Fire Safety NZ , Fire Compliance , Fire Safety Information: Firewatch NZ is a 100% Kiwi specialist fire protection company with agents across New Zealand including

[Contact Us](#)



Buy Underground Depot Box New Zealand , FSP New

Buy top quality Underground Depot Box from a leading manufacturer in New

[Contact Us](#)



Passive Fire. Firestop Centre brings together Passive Fire Protection

Welcome To Firestop Centre Your first stop for passive fire protection. Top brands, expert advice, fast delivery. Get proven, tested, compliant solutions from leading local and global manufacturers.

[Contact Us](#)

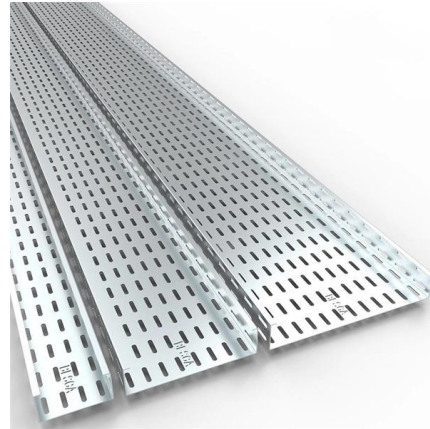

Boxes , New Zealand Post

Size 4 Box o 10 Pack Size 4 Boxes o For sending parcels within New Zealand and internationally o Size: 318mm x 216mm x 507mm o Cost for single item: \$6.50 o Has a minimum of 50% recycled content.

[Contact Us](#)

Viking Sales and Services Ltd

Manufacturer and wholesaler of fire safety supplies to the New Zealand Fire Industry.

[Contact Us](#)

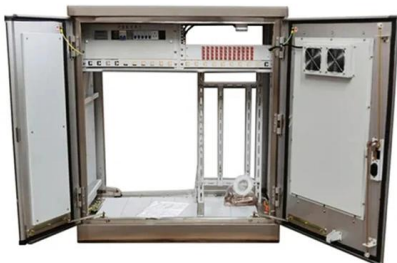

Dizzy or Distribution Boxes - Skellerns Foundry

Additional information Dizzy or Distribution Box Sizes 2x700EF, 3x700EF, 4x700EF, 5x700EF, 6x700EF, 8x400EF

[Contact Us](#)



Distribution & Termination Boxes

Shop for Distribution & Termination Boxes from leading brands at PBTech .nz

[Contact Us](#)



Fire Doors , Largest Manufacturer of Fire Doors in New

Fire Doors As the largest manufacturer of fire doors in New Zealand, Pacific Doors has been at the forefront of the industry for over 20 years. Through constant

[Contact Us](#)



Orbital Fire Ltd. - Partners in Fire Protection

Explore our comprehensive range of fire protection products below, designed to meet the needs of every project. You'll also find links to our online product catalogues

[Contact Us](#)

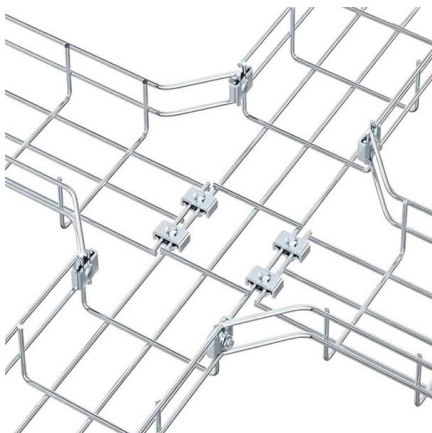
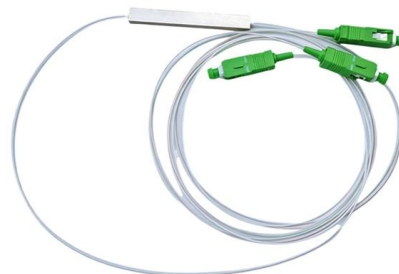

Fire stopping systems with regard to Flush Boxes

Recently the spotlight has been put upon Fire stopping systems with regard to Flush Boxes. It has been highlighted that many Fire rated pads being

[Contact Us](#)



Custom Fire Alarm Packaging Boxes Wholesale , CBZ

Protect and promote with custom fire alarm packaging & boxes. Wholesale, logo-printed, and eco-friendly designs available for sale at CustomBoxesZone.

[Contact Us](#)



Suntree Fireproof Distribution Box , Waveinverter

Fireproof distribution box, surface mounted, large enough for 6 DIN,

[Contact Us](#)



Suburbia Firebox - Fernside Fires

Suburbia Fire Box: Measuring 972mm wide and 3462 high (sitting on a bottom bin), 5mm New Zealand steel internal firebox, wrapped in a 25mm 1500 degree

[Contact Us](#)



Westpeak Fire Protection , Westpeak(TM) New Zealand

Westpeak New Zealand provides fire protection equipment, safety harness equipment, for businesses & industries, NZ wide. Browse our website now and shop online!

[Contact Us](#)



Passive Fire. Firestop Centre brings together Passive

Welcome To Firestop Centre Your first stop for passive fire protection. Top brands, expert advice, fast delivery. Get proven, tested, compliant solutions from leading

[Contact Us](#)



Fire Safety Equipment for sale , NZ Safety Blackwoods

Fire extinguishers, blankets and equipment for NZ workplaces. Choose the right fire protection with expert guidance from NZ Safety Blackwoods.

[Contact Us](#)

Distribution & Termination Boxes

Dynamix FWEIP48 Lockable Indoor/Outdoor Fibre Termination Box. 48 position SC Simplex. IP65, UVResistant.

[Contact Us](#)



Fire Extinguisher Equipment

Are you looking for top-quality fire extinguisher equipment supplier in New Zealand? We offer a wide range of fire safety products such as fire extinguisher box at the

[Contact Us](#)



Fire Systems , ArchiPro NZ

ArchiPro features only the best fire systems in New Zealand, one of the most important aspects of residential and commercial building development. Fire systems consist of multiple devices that work

[Contact Us](#)



Distribution Boards , Meterboxes & Circuit Breakers

Distribution Boards, Meterboxes & Circuit Breakers from Electrical Direct Ltd,

[Contact Us](#)

Suntree Fireproof Distribution Box , Waveinverter

Fireproof distribution box, surface mounted, large enough for 6 DIN, e.g. three 2 pole circuit breakers.

[Contact Us](#)

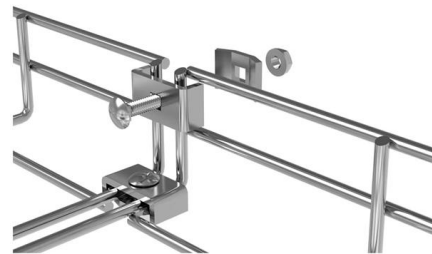

Westpeak Fire Protection , Westpeak(TM) New Zealand

Westpeak offers a wide range of fire protection products designed to keep you and your staff should the worst happen. Our fire protection products include both in-car and workplace solutions, including

[Contact Us](#)



Meter Boxes , Meterboxes & Circuit Breakers

Online electrical suppliers of NZ Standards compliant outdoor meter boxes and flashing kits, domestic fuse boxes (switchboards), switches and sockets.

[Contact Us](#)



Contact Us

For datasheets, pricing, or custom fiber access solutions, please visit:
<https://frindel.es>