

Power Configuration Diagram of Level 3 Distribution Box

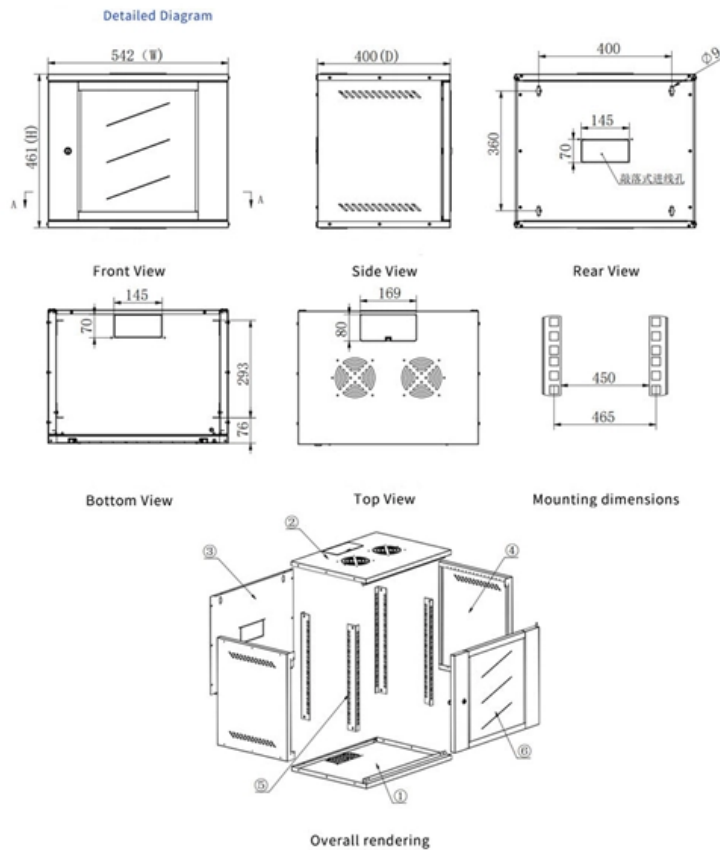



Power Configuration Diagram of Level 3 Distribution Box

Distribution Automation Handbook



In the following, the distribution power transformer features, construction and protection and their influence to the complete distribution system performance are discussed.

[Contact Us](#)

Power Distribution Box Essentials: Functions, Types

Both ordinary distribution and ex-proof distribution power boxes serve the same purpose of safe power distribution, but each is suitable for different

[Contact Us](#)



The Essential Guide to Understanding Electrical

Understanding the power source is crucial as it helps you trace the power flow and identify potential issues or limitations. 3. Follow the power flow: Electrical

[Contact Us](#)

SECTION 9: ELECTRICAL POWER DISTRIBUTION

3 The Electrical Grid Three main components to the electrical grid Generation ESE 450
Transmission Transmission Subtransmission
Distribution Primary distribution Secondary distribution Different



3 Phase Distribution Board Layout and Wiring Diagram / Three phase

In this video, I try to explain three phase distribution board layout and wiring diagram. Three phase power supply is required, when the Power distribution requirement cannot be handled by a

[Contact Us](#)



PRODUCTION NAME	Frequency conversion control cabinet
PROTECTION DEGREE	IP55
VOLTAGE	220/380V
SIZE	customized as required
MOUNTING WAY	Floor -standing
APPLICATION	Indoor and outdoor

Size determination, installation method and wiring mode

The distribution box is the central hub of the home circuit and the general control of our daily power consumption. It is an indispensable electrical equipment. If there

[Contact Us](#)



- IP65/IP55 OUTDOOR CABINET
- OUTDOOR TELECOM CABINET
- OUTDOOR ENERGY STORAGE CABINET
- 19 INCH

Planning of Electric Power Distribution

This comprises software tools and support for planning and configuring as well as a perfectly harmonized, complete portfolio of products and systems for integrated power distribution, ranging

[Contact Us](#)





3 Phase Panel Diagram

It not only ensures reliable and efficient power distribution but also offers numerous benefits, such as increased capacity and improved power quality. As our

[Contact Us](#)



How to classify power distribution cabinet and power

1) Primary power distribution equipment is collectively referred to as power distribution center. They are centrally installed in the enterprise's substation and

[Contact Us](#)



Power Distribution Systems

The function of the electric power distribution system in a building or an installation site is to receive power at one or more supply points and to deliver it to the lighting loads, motors and all other

[Contact Us](#)

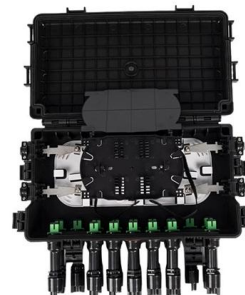

The difference between the first, second, and third levels of

Secondary distribution box: distribution boxes for each floor or building (according to actual conditions); Third level distribution box: refers to the final junction box of each electrical

[Contact Us](#)



3 Phase Distribution Board MCCB Wiring Diagram

Complete wiring diagram for 3 phase distribution board with MCCB, showing connections for incoming supply, breakers, and load distribution for safe

[Contact Us](#)



3 Phase Distribution Board Diagram For Multi Story House

A complete guide about 3 phase distribution board diagram or three phase wiring installation in multi story house or building In Urdu & Hindi.

[Contact Us](#)

Step-by-Step Guide to Wiring a 3 Phase DB Box

Learn about the wiring process for a 3 phase distribution board (DB) box, including the necessary steps and safety precautions. Understand how to connect the

[Contact Us](#)



Three (3) Phase Distribution Board Wiring Diagram and

Hey, in this article we are going to see the Three (3) Phase Distribution Board Wiring Diagram and Connection Procedure. The three-phase distribution

[Contact Us](#)



Planning of Electric Power Distribution

To this end, we are launching a new series, whereby volume 2 will consist of several individual modules. This newly designed first volume, "Planning of Electric Power Distribution - Technical Principles",

[Contact Us](#)

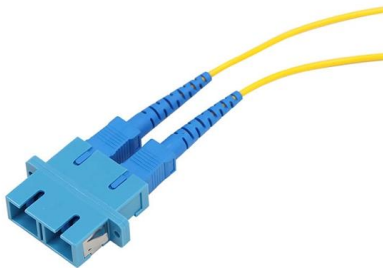

Three-Tier Power Distribution System in a Newly Constructed

In a newly constructed residential area, a 10kV power line is introduced into the substation. After stepping down the voltage through the transformer's low-voltage side (0.4kV), power distribution is

[Contact Us](#)

How To Make 3 Phase Distribution Board In MCCB Wiring Diagram , 3

This video shows 3 Phase Distribution Board In MCCB Wiring Diagram. 3 phase distribution (DB) box 3-phase rack PDU, is spread evenly across all three phases (L1/L2, L2/L3, and L3/L1). It can be



[Contact Us](#)



3 phase distribution DB box wiring diagram

Three Phase Distribution DB box Connection. what is a three phase line? In electrical engineering three phase electric power systems have at least three conduc

[Contact Us](#)



POWER DISTRIBUTION BOX ASSEMBLY GUIDE

Phase 3's Powersafe Sequential Mating Box controls the connection sequence of incoming / outgoing high current cable connections. The sequence ensures that the Earth connection is made first and

[Contact Us](#)



Understanding Distribution Boxes: A Comprehensive Guide

A distribution box, also known as a power distribution box or electrical distribution box, is used to distribute electrical power safely to multiple

[Contact Us](#)



Three Phase Distribution Board Wiring Diagram

The three phase distribution board wiring diagram is a diagram of the connections between the power sources, the various components of the three

[Contact Us](#)



POWER DISTRIBUTION BOX ASSEMBLY GUIDE

Thank you for purchasing the Powersafe Power Distribution Box Phase 3's Powersafe Sequential Mating Box controls the connection sequence of incoming / outgoing high current cable connections. The

[Contact Us](#)



Wiley Online Library , Scientific research articles, journals, books

Hier sollte eine Beschreibung angezeigt werden, diese Seite lässt dies jedoch nicht zu.

[Contact Us](#)



3 Phase Power Distribution Box: Safety, Efficiency, and

Discover the essential functions and advantages of the 3 phase power distribution box for effective power management. Learn how its advanced features provide

[Contact Us](#)



Electrical Power Distribution System:

The electric power distribution diagram is shown below. Power plants are located in remote areas from where it has to be transmitted to a distribution

[Contact Us](#)



Industrial 3 Phase Electrical Distribution Box Guide

Explore the essentials of industrial 3 Phase Electrical Distribution Box for efficient power management in commercial settings. Get expert insights now.

[Contact Us](#)

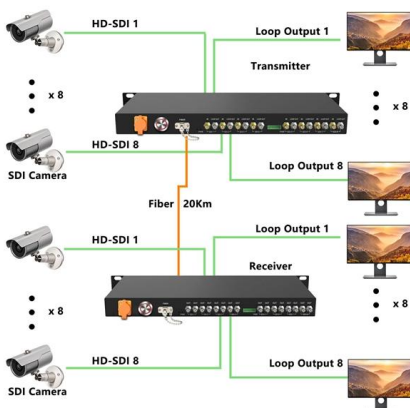



Wiring Diagram Of A 3 Phase Distribution Board

When it comes to electrical power distribution, one of the most important tasks is getting the wiring diagram of a 3-phase distribution board set

[Contact Us](#)



Step-by-Step Guide to Wiring a 3 Phase DB Box

By following these steps and adhering to safety guidelines, you can properly wire a 3 phase db box and ensure the efficient and safe distribution of electrical power in

[Contact Us](#)

Contact Us

For datasheets, pricing, or custom fiber access solutions, please visit:
<https://frindel.es>