

Outdoor power distribution box track installation

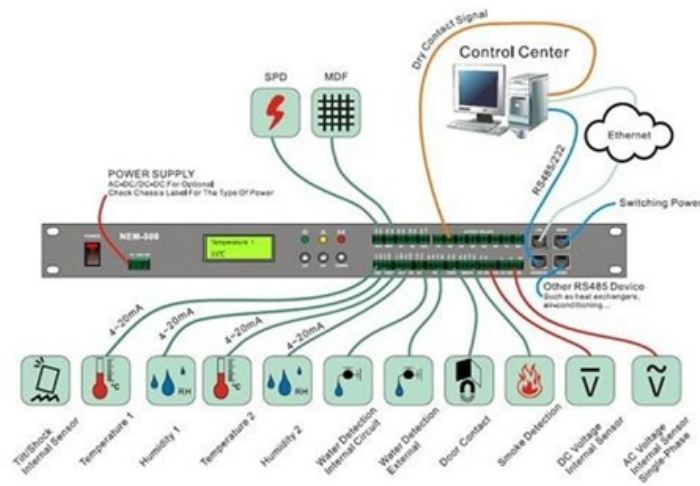



Outdoor power distribution box track installation



Install Track Lights

If no junction box is available along the proposed path of the lighting track, you will need to install one or have it installed by a qualified electrician. This

[Contact Us](#)

Busbars: why you should install underfloor power , CMD

Traditionally, busbars are the power distribution systems that carry and distribute electricity throughout industrial premises. In offices, the term "busbar" usually



[Contact Us](#)



How to Add an Outdoor Electrical Box (DIY) , Family

Add an outdoor electrical box to get power to where you need it, especially for holiday lights. Do it safely and easily.

[Contact Us](#)

How to Install a Distribution Box--A Comprehensive

Whether you are an electrical contractor or a construction brigade, knowing how to properly and safely install distribution boxes is the basis of



How To Safely Install an Outdoor Electrical Box for Your

Tip: If installing a junction box for power tools, choose a metal conduit for added durability. How Much Does It Cost to Put in an Outdoor Electrical Box? The cost

[Contact Us](#)



Safe Outdoor Electrical Panel Installation Guide

Learn how to complete a safe, code-compliant Outdoor Electrical Panel Installation with the right tools, PPE, and Linkewell's weatherproof power

[Contact Us](#)



How to Mount Outdoor Electrical Panels Safely and

Learn how to mount outdoor electrical panels safely with proper methods, code requirements, materials, and installation steps for long lasting

[Contact Us](#)

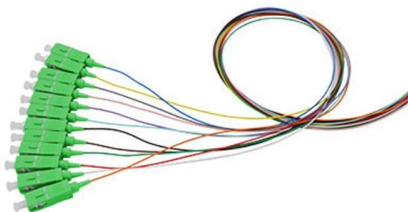



Installing an Outdoor Socket or Exterior Power Point

Regulations on Installing Outdoor Sockets Where Should You Put An Outdoor socket? Do Outdoor Sockets Need to Be Waterproof? Types of Exterior Socket Tools and Materials Needed For An Outdoor socket? Installing An Outdoor Socket For the purposes of this example, our electrician will be wiring up an outdoor socket in a rear garden, some way from the property so will be running SWA cable to the location. As there isn't an available 30mA circuit, he will also be installing a new MCB in the consumer unit that itself will be protected by the required RCD as it was a zoned board See more on [diydoctor .uk/burland](http://diydoctor.uk/burland)



Burland Connect Under Floor Track - Burland

Manufactured in the UK, the Burland Connect power track system meets all under floor power distribution needs and is colour coded to ensure compliance with

[Contact Us](#)

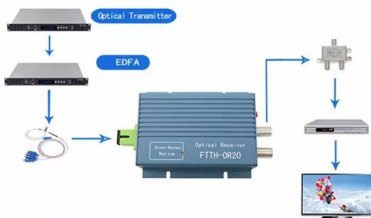

INSTALLATION MANUAL REMOTE POWER SYSTEM: DISTRIBUTION BOX

INSTALLATION MANUAL REMOTE POWER SYSTEM: DISTRIBUTION BOX delivers full new and Applications - A streamlined full system solution backed with industry leading reliability and

[Contact Us](#)

INSTALLATION INSTRUCTION L Track Systems

Check with a qualified electrician before wiring. All installation shall be in accordance with NEC and all local codes Save these installation instructions and refer to them when additions or changes to the



[Contact Us](#)



The Ultimate Guide to Power Track Sockets: Revolutionizing Your

Explore the revolutionary advantages of power track sockets: flexibility, safety, and efficiency. Learn about their operation, types, applications, installation, and maintenance.

[Contact Us](#)

Kaggle

" 'power',n", " 'success',n", " 'people',n", " 'different',n", " 'situation',n", " 'encounter',n", " 'br',n", " 'br',n", " 'variation',n", " 'arthur',n", " 'schnitzler',n", " 'play',n", " 'theme',n", " 'director',n",

[Contact Us](#)

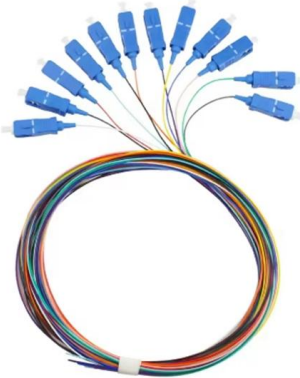
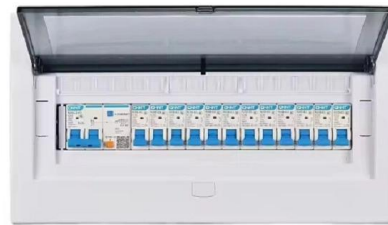

Track System Installation Guide

Place track rail under junction box in desired position, rotate ground clip to insert track rail, and push it into clip, until ground clip is securely inserted into track side grooves.

[Contact Us](#)

The Ultimate Guide to Power Track Sockets: Revolutionizing Your

Explore the revolutionary advantages of power track sockets: flexibility, safety, and efficiency. Learn about their operation, types, applications, installation, and maintenance. This

[Contact Us](#)



| | |
|------------------|--------------------------------------|
| PRODUCTION NAME | Frequency conversion control cabinet |
| POTECTION DEGREE | IP55 |
| VOLTAGE | 220/380V |
| SIZE | customized as required |
| MOUNTING WAY | Floor -standing |
| APPLICATION | Indoor and outdoor |



Mitsubishi outdoor and branch box installation

This video covers the installation of a 60K BTU/hr outdoor unit and the associated branch distribution box. The previous video at: o Mitsubishi split AC install - indoor units covers the

[Contact Us](#)

ephesus-remote-distribution-installation-manual

INSTALLATION MANUAL REMOTE POWER SYSTEM: DISTRIBUTION BOX POWER & CONTROLS (PAC) delivers full both new and full turn-key system solution backed with industry leading reliability

[Contact Us](#)



Power Distribution Boxes Explained Simply

Discover the essentials of a Power Distribution Box--how it works, key types, benefits, and tips to ensure safe, efficient electrical power management.

[Contact Us](#)

Outdoor Cut Outs and Distribution Boxes

Lucy Electric's range of low voltage outdoor cut outs and distribution boxes is engineered for durability, safety, and ease of installation in demanding

[Contact Us](#)



MPO-MPO Low Smoke Halogen Free Sheath

Multimode 10 Gigabit 24 pole OM3

Insertion loss <0.35dB Return loss >50dB



"Power Track Installation Guide , Step-by-Step Wiring & Tools

"Want to install a power track system safely and efficiently? This video provides a complete step-by-step guide for electricians and DIY enthusiasts.

[Contact Us](#)

Understanding Outdoor Power Distribution Box: A

Conclusion Outdoor power distribution boxes are an essential component of any outdoor power setup. Whether you're organizing an event,

[Contact Us](#)



Contact Us

For datasheets, pricing, or custom fiber access solutions, please visit:
<https://frindel.es>