

Opening of switch in distribution box





Overview

Place a padlock through the switch where possible, to lock it in the off. Proper construction techniques are essential for the protection and durability of electrical systems. A distribution box, also known as a distribution board, electrical panel, or breaker box, is an enclosure that houses electrical components responsible for distributing electricity throughout a building. The purpose of this method is to highlight safe working practices for electrical isolation which is similar as lock out tag out. Operators must wear necessary PPE as required by local conditions and task specific risk assessment. According to the electrical design requirements, determine the appropriate installation location and.



Opening of switch in distribution box



What is an Electrical Distribution Box? A

Opening up an electrical distribution box might look like stepping into a maze of wires, switches, and mysterious gadgets. But each component plays a

[Contact Us](#)

The Importance of Distribution Boxes in Electrical Systems

Learn more about how distribution boxes play a critical role in the safe and efficient operation of electrical systems.

[Contact Us](#)



What is the Internal Structure of The Distribution Box

Learn about the internal structure of a distribution box, its components, functions, and key types. Understand its role in electrical systems

[Contact Us](#)



How to Install a Distribution Box--A Comprehensive

Before starting the installation, finding a proper place for putting the distribution box is crucial, because it largely decides the safety and convenience

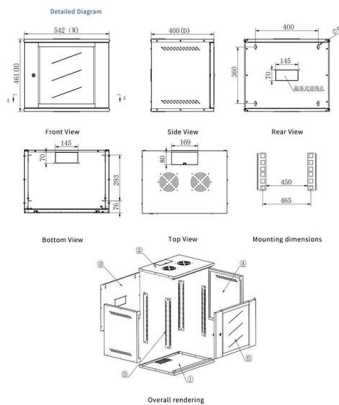

Single Phase Distribution Box Wiring Diagram for

Single Phase Distribution Box Wiring Diagram for Beginner (DB Wiring) What is Distribution Board? Distribution board is a safe system designed for house or

[Contact Us](#)

Wiring diagram for a switch box: Clear and concise guide

Learn how to read and understand a switch box wiring diagram. Find out how different connections are made and how to troubleshoot common issues.

[Contact Us](#)

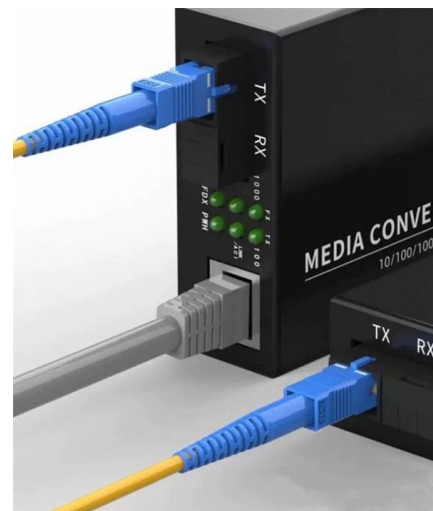

Kaggle

"Requirement already satisfied: smart-open>=1.8.1 in /opt/conda/lib/python3.7/site-packages (from gensim) (5.2.1)rn", "Requirement already satisfied: scipy>=0.18.1 in /opt/conda/lib/python3.7/site

[Contact Us](#)





Cautions and Requirements for Installation of

In normal operation, the circuit can be switched on or off by manual or automatic switch. When a fault or abnormal operation occurs, the circuit is cut off or the

[Contact Us](#)



Size determination, installation method and wiring mode

The distribution box is the central hub of the home circuit and the general control of our daily power consumption. It is an indispensable electrical equipment. If there

[Contact Us](#)

How to Read a Breaker Box: Expert Tips for Navigating

Still scared of that big gray and black box in your utility room? Here is an easy guide to understanding how to read your breaker panel! Call Mr. Electric

[Contact Us](#)



The Importance of Isolation Switches in Distribution Boxes

Most isolation switches use either a lever or a rotary handle to open or close the contacts. When the handle is moved to the off position, the contacts

[Contact Us](#)



The purpose, working principle, and usage instructions

The installation position of the switch box should be as close as possible to the controlled electrical equipment according to the on-site situation

[Contact Us](#)



Distribution Box Installation: A Complete Guide to Safe

Mount the distribution box in a convenient, accessible location that complies with local electrical codes. Typically, this is in a basement, utility room, or garage.

[Contact Us](#)

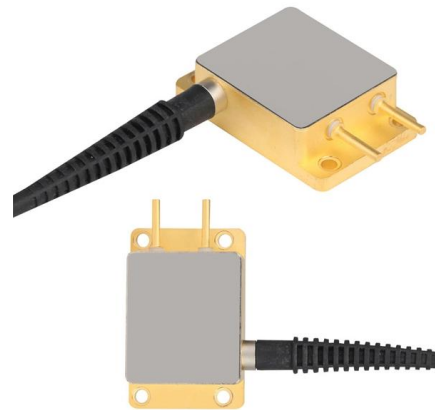

Summary of key points for construction and installation of distribution

The construction and installation points of distribution boxes and switch boxes are summarized as follows: 1. Select qualified products that meet national standards and safety requirements.

[Contact Us](#)

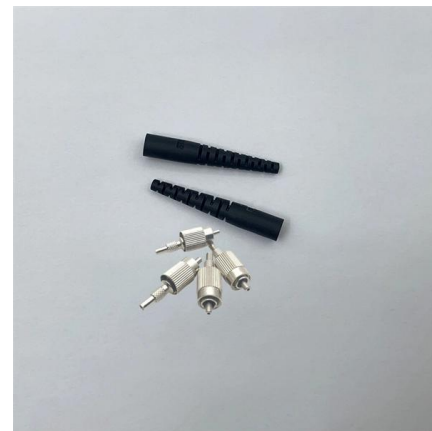

Business Standard

Hier sollte eine Beschreibung angezeigt werden, diese Seite lässt dies jedoch nicht zu.

[Contact Us](#)



The purpose, working principle, and usage instructions

During normal operation, the circuit can be connected or disconnected using manual or automatic switches. When there is a malfunction or

[Contact Us](#)



Understanding Distribution Boxes:A Comprehensive Guide

A distribution boxes is an essential device that manages the safe and efficient flow of electrical power throughout different areas of a building or facility.

[Contact Us](#)



Understanding The DP Box And DP Switch: Electrical Power Distribution

Let's look at some of its advantages: Effective Power Distribution: The DP Box ensures that power is distributed evenly among customers by segmenting the electrical supply into several

[Contact Us](#)

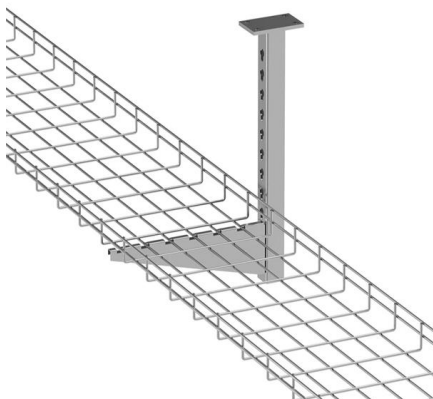

How to Wire a Home Distribution Box

FDB (Final Distribution Board) directly connected through SDB (Sub Distribution Board) and the final switches are used to control the connected

[Contact Us](#)



Electrical Isolation in Distribution Board Safework

Place a sign on the switch and the DB saying "Electrician working do not switch on". Return to the circuit you wish to isolate and carry out a test to see if it is now dead.

[Contact Us](#)

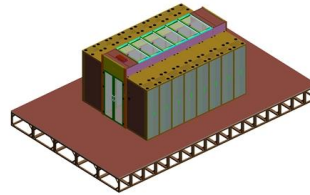

AS/NZS 3000 Switchboard Rules - Complete Guide for

Switchboard rules is critical for ensuring electrical safety and functionality. Proper construction techniques are essential for the protection and

[Contact Us](#)

Distribution boards components

The consumer is allowed to operate this circuit breaker or switch if necessary (e.g. to reclose it if the circuit breaker has tripped due to current consumption exceeded the authorized limit,

[Contact Us](#)



on video How to Wire a Home Distribution Box

How to Wire a Home Distribution Box - Step-by-Step , Distribution DB box wiring diagram
Welcome to our channel! In this video, we'll walk you through the

[Contact Us](#)



How to Install and Wire a Switch Box: A Step-by-Step

Are you looking for a wiring diagram for a switch box? This article provides a detailed guide on how to wire a switch box correctly, including the different types of

[Contact Us](#)



The Complete Guide to Distribution Box: Installation, Types & More

Each element plays a specific role in ensuring safe electrical distribution. The main switch, or main breaker, controls the entire electrical supply to the distribution box. This large switch allows

[Contact Us](#)

Contact Us

For datasheets, pricing, or custom fiber access solutions, please visit:
<https://frindel.es>