

Mozambique National Standard Explosion-proof Distribution Box Company

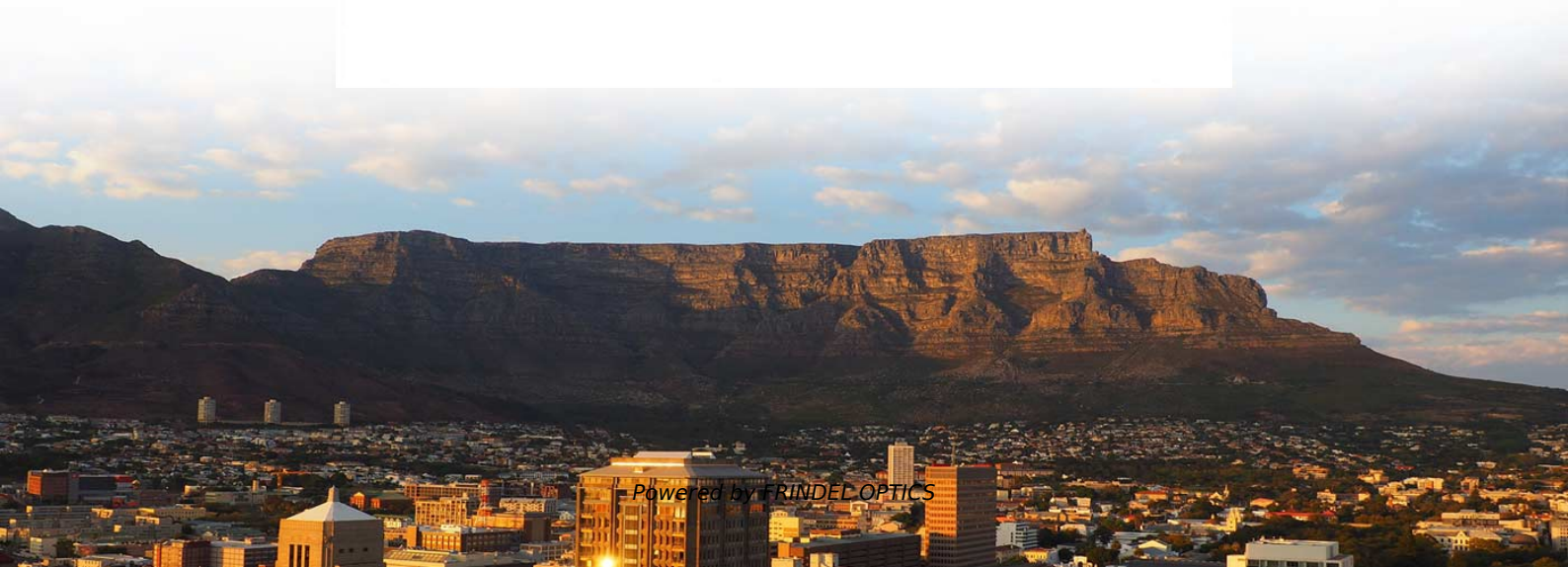

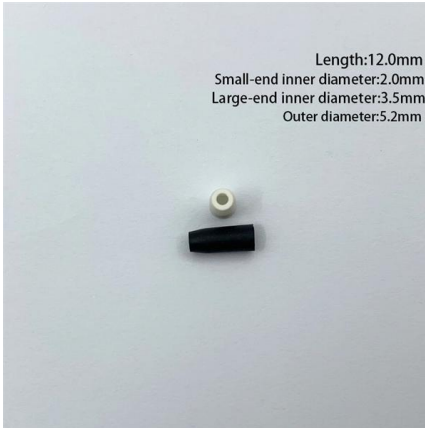

Mozambique National Standard Explosion-proof Distribution Box Co



Explosion-Proof Lights, Explosion-Proof Junction Box,

Our products have passed rigorous explosion-proof performance testing by a nationally accredited agency, securing the necessary explosion-proof

[Contact Us](#)

Global Explosion-Proof Distribution Box Market Size, Growth Trends

Delve into detailed insights on the Explosion-Proof Distribution Box Market, forecasted to expand from USD 2.5 billion in 2024 to USD 4.1 billion by 2033 at a CAGR of 5.6%. The report

[Contact Us](#)

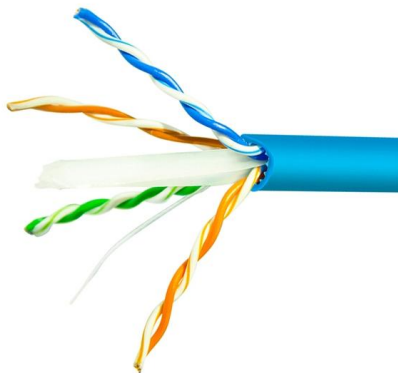

Explosion proof distribution box standards and installation issues

All components and technical parameters need to comply with the national standard GB7251 design requirements, sample production needs to be notified to the construction unit, supervision,

[Contact Us](#)

What is Explosion Proof Distribution Box?

Conclusion: Ensuring Safety with Explosion Proof Distribution Boxes Explosion Proof Distribution Boxes are indispensable in ensuring safety and operational continuity

[Contact Us](#)



Explosion Proof Enclosure Comprehensive Guide

Explosion-Proof Distribution box: These smaller components are structurally similar to distribution cabinets. You can use these for the distribution

[Contact Us](#)



Custom CZ1290 Explosion-proof distribution boxes

About CZ CZ Electric Co., Ltd was established in 1990, is a CZ1290 Explosion-proof distribution boxes (socket with transformer) suppliers, and is headquartered in

[Contact Us](#)



Explosion Proof Distribution Boxes

For more information on our range of explosion proof distribution boxes please click on the links above or contact us at ex@warom.ae

[Contact Us](#)





Standard Explosion-Proof Distribution Box BX51 , Download

BX51 Convention Explosion-Proof Distribution Box delivers safe power control and distribution in explosive-prone environments.

[Contact Us](#)

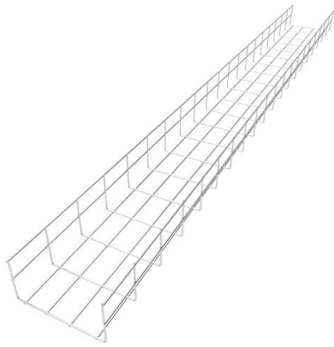

Mozambique

Overview Standards Testing, Inspection, and Certification Publication of Technical Regulations The Instituto Nacional de Normalização e Qualidade (INNOQ), or the National Institute for Normalization and Standards in Mozambique, is the national standards body. Established in 1983 under Mozambique's Ministry of Industry and Energy, INNOQ is responsible for defining and implementing quality policy. INNOQ also coordinates all standardization and See more on [trade.govcz-ex](#)

Ex Isolation Switch/Safety Switch/Circuit Breaker Manufacturers

The company's products adopt international advanced technology and are designed and manufactured in strict accordance with IEC international standards and ATEX EU standards.

[Contact Us](#)

Explosion Proof Device Box Factory

MINMILE Operates As Explosion Proof Device Box Factory And Supplier, Producing Compact Protective Housings Enabling Safe Device Integration In Harsh Fields.

[Contact Us](#)





Dry Powder Fire Extinguishers (Mozambique Standard)

Dry Powder Fire Extinguishers 1. Introduction and Regulatory Framework In Mozambique, fire safety is governed by a framework of regulations and standards designed to mitigate risks in a

[Contact Us](#)

Explosion Proof Distribution box-

Explosion Proof Distribution box is applicable to explosive gas mixture Hazardous locations: Zone 1, Zone 2, Zone 20, Zone 21, Zone 22;explosive gas mixture: II A, II B, II C level;the temperature

[Contact Us](#)



Explosion-Proof Distribution Boxes & Panels Manufacturer

The explosion-proof distribution box safely delivers power in hazardous zones (oil, gas, chemical plants) with rugged, spark-resistant casing--ATEX/IECEX, IP66 certified for reliable operation in explosive

[Contact Us](#)

Explosion Proof Enclosures , Complete Hazardous Area

Learn everything about explosion proof enclosures for hazardous areas--design, certification, and industrial applications with ATEX, IECEX, and Class I Div

[Contact Us](#)





What is Explosion Proof? A Look Into Control Panels

Examples of Explosion-Proof Enclosures One example of explosion-proof standards is shown by ADALET enclosures' products. The company

[Contact Us](#)



Industrial and commercial standards in Mozambique

Find out about the national standards and certification bodies in Mozambique. Consult the online catalogue of standards and their classification.

[Contact Us](#)



Mozambique fire energy storage box

The solvent-based fire retardant coating market for energy storage boxes is shaped by a mix of specialty chemical manufacturers and industrial coating specialists.

[Contact Us](#)

How to Wire an Explosion-Proof Distribution Box and

1. Wiring an Explosion-Proof Distribution Box When installing and wiring an explosion-proof distribution box, it is essential to follow strict safety protocols and

[Contact Us](#)



Energy Distribution



BARTEC offers one of the most extensive ranges of explosion-proof and substance-resistant components, devices, and systems for controlling, switching, and

[Contact Us](#)

Technical Specification for Explosion Proof Cabinets: A Guide

Developing a precise technical specification for explosion proof cabinets is fundamental for safety and operational integrity in hazardous environments. These specifications dictate the

[Contact Us](#)

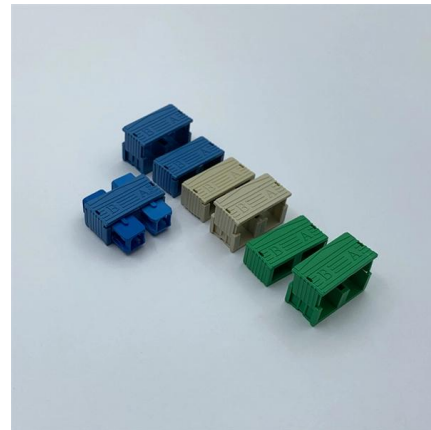

Explosion Proof Distribution Box & Electrical Enclosures

Durable Hexlon Explosion Proof Distribution Boxes and Electrical Enclosures, IECEx and ATEX certified for Zone 1 and Zone 2.

[Contact Us](#)



Explosion-Proof Distribution Box Market -

The explosion-proof distribution box market is driven by high-risk sectors where flammable gases or dust can exist, requiring equipment that prevents ignition and meets stringent

[Contact Us](#)



Explosion Proof Certification , SGS



6WAY EXPLOSION PROOF DISTRIBUTION BOXES,

FOR EXPLOSION-PROOF PLUG 16A, 32A CAN BE SELECTED. WIRING IS FINISHED IN THE SOCKET BOX. REASONABLE ARRANGEMENT AND

[Contact Us](#)

Mozambique

Our explosion proof certification services provide you with third-party conformity assessments and access to various certification schemes, including ATEX, TR CU (EAC), USTC (US and Canada),

[Contact Us](#)

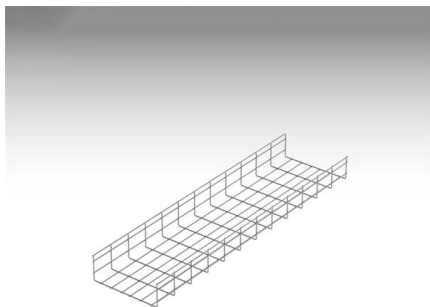

Grid Cable for marine and offshore applications

Flameproof Distribution Board , Explosion proof

An ordinary distribution board may generate heat and sparks due to heavy usage. Thus, the flameproof/explosion-proof distribution box/panel is used in hazardous

[Contact Us](#)

Contact Us

For datasheets, pricing, or custom fiber access solutions, please visit:
<https://frindel.es>