

Mongolian Explosion-proof Lighting and Power Distribution Box

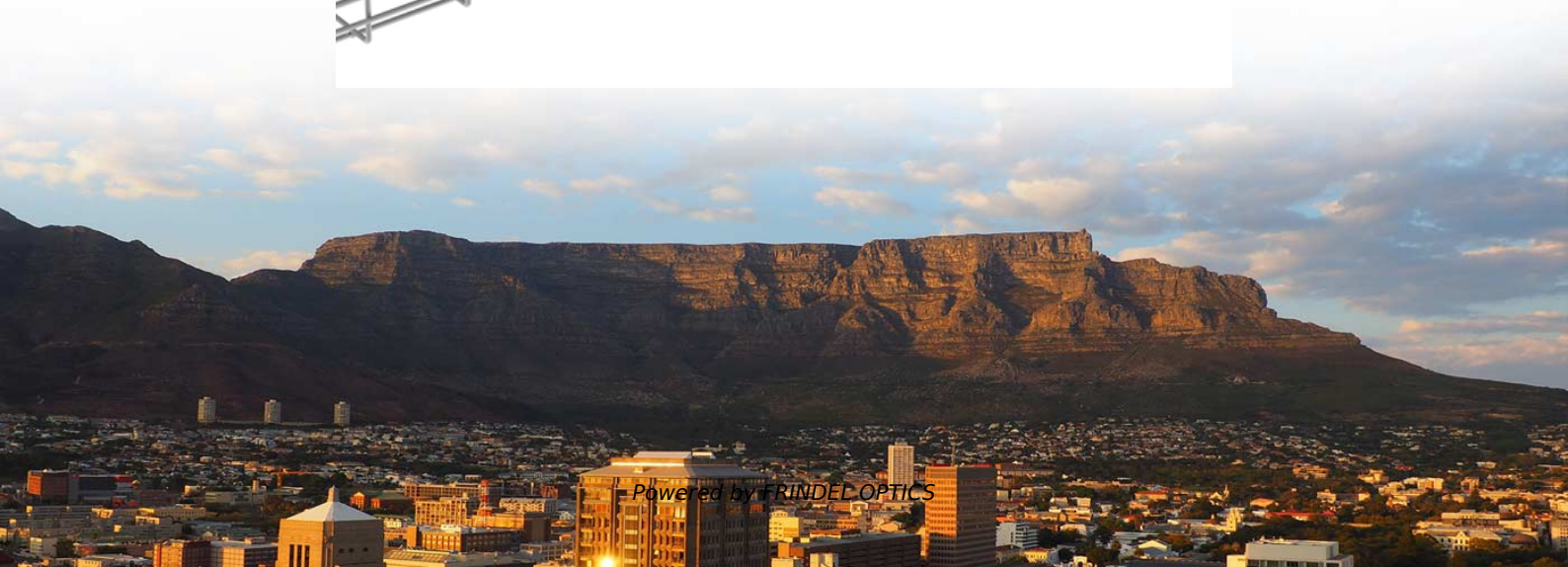

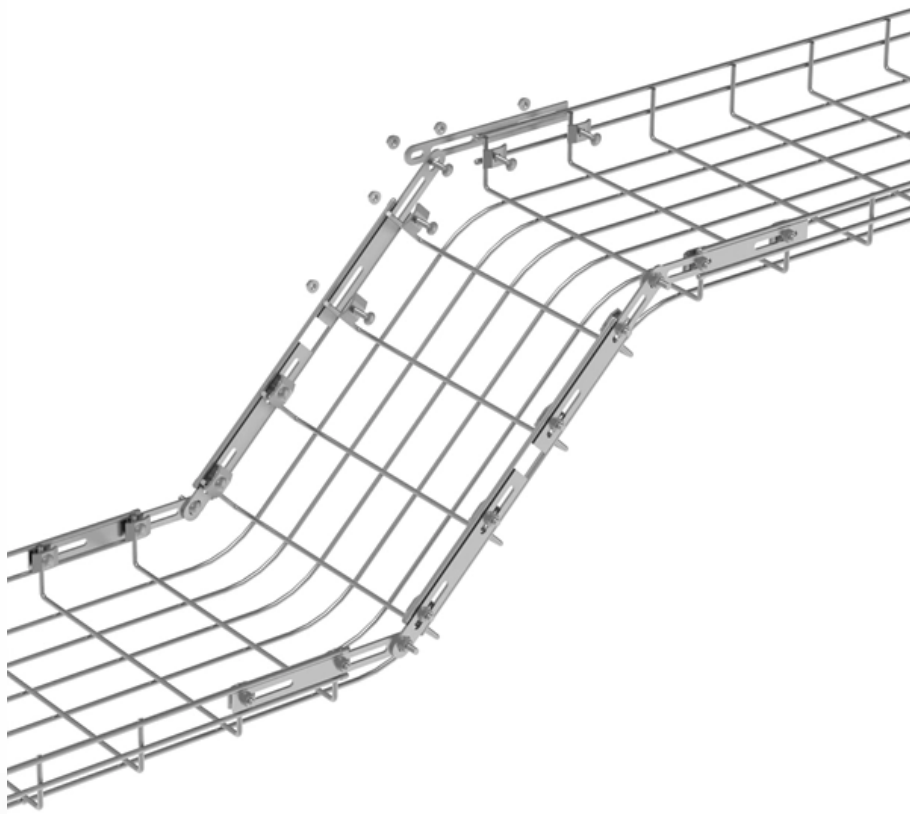

Overview

Introducing our Explosion-proof Lighting (Power/Repair) Distribution Box, designed for enhanced safety and efficiency in hazardous environments. This series of products have good explosion-proof function, suitable for IIA, IIB, IIC explosive gas environment and various flammable and explosive sites, mainly used in railway, power, metallurgy, petroleum, petrochemical, chemical, iron and steel, aviation, ships and various factory areas. Explosion-proof lights used in hazardous areas where combustible gases and dust exist, which can prevent arcs, sparks, and high temperatures that may occur inside the lamp from igniting combustible gases and dust in the surrounding environment, thus meeting explosion-proof requirements. This robust distribution box complies with IIB/IIC/tD standards, ensuring reliable performance in explosive atmospheres. (hereinafter referred to as KGV Electric), founded in 2011, is a high-tech enterprise focusing on the R&D and manufacturing of explosion-proof electrical appliances and industrial lighting.



Mongolian Explosion-proof Lighting and Power Distribution Box



Songbei Explosion-proof Anti-Corrosion Lighting Power Distribution

With its sturdy construction and advanced protection features, this distribution box is ideal for controlling and distributing electrical power in areas where explosive gases or hazardous substances may be

[Contact Us](#)

Explosion-proof lighting (power/repair) distribution box

This robust distribution box complies with IIB/IIC/tD standards, ensuring reliable performance in explosive atmospheres. Ideal for industrial settings, it provides secure power distribution and repair

[Contact Us](#)



explosion proof light box-Explosion Proof Electric

BXM (D) Explosion proof Lighting (Power) Distribution Box This series of products have good explosion-proof function, suitable for class II A, II B, temperature group

[Contact Us](#)



BXM (D) series explosion-proof lighting (power) distribution box

Its products cover explosion-proof distribution boxes, LED explosion-proof lamps, explosion-proof instrument control boxes, etc., and are widely used in petroleum, chemical, power, metallurgy and



BXM (D)81 Explosion proof Distribution Boxes Lighting

BXM (D)81 Explosion proof Distribution Boxes Lighting or Power Explosion protection to -CENELEC -IEC -NEC Can be used in Zone 1 and Zone 2 Zone 21 and Zone

[Contact Us](#)



Distribution Boxes

Distribution Boxes BXM (D)51 Series Explosion proof Distribution Boxes Lighting/Power (Ex d e IIB) Distribution Boxes BXM (D)53 Explosion proof

[Contact Us](#)



BXM(D)8050 Series Explosion Proof Lighting

Enclosure of the explosion-proof illumination distribution panels treated with anti-static coating and all fasteners are anti-loosening. The operating switch panel on

[Contact Us](#)

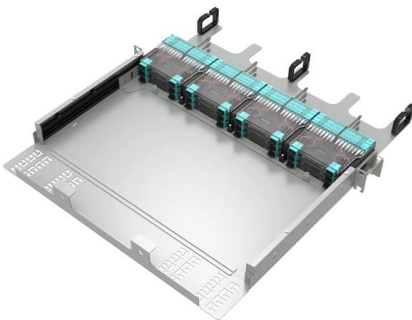



Songbei Explosion-Proof Anti-Corrosion Lighting Power Distribution

Perfect for industrial applications, this distribution box ensures safe and reliable electrical power distribution while protecting your equipment and personnel from explosion risks.

[Contact Us](#)



Expert Guide: Select the Right Temporary Power Distribution Box

The right distribution box that matches your power requirements, durability needs, and weather resistance will give optimal performance for specific applications. Note that successful power

[Contact Us](#)



Explosionproof stainless steel lighting (power)

This series of products have good explosion-proof function, suitable for IIA, IIB, IIC explosive gas environment and various flammable and explosive sites, mainly

[Contact Us](#)



Explosion-Proof Lights, Explosion-Proof Junction Box, Explosion-Proof

Shenhai: With 25 years of expertise, we lead in manufacturing high-quality explosion-proof lights, junction boxes, and pipe fittings for hazardous environments.

[Contact Us](#)





BXM (D) Explosion proof Lighting (Power) Distribution Box

Reliable explosion-proof lighting power distribution boxes that are shock-resistant, durable, energy-efficient, and certified for various industries with a complete range of models and styles.

[Contact Us](#)

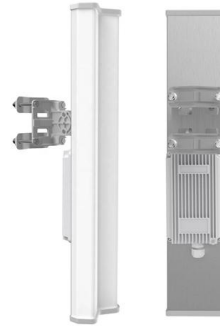

BXM (D) series explosion-proof lighting (power) distribution box

BXM (D) series explosion-proof lighting (power) distribution box can be specially designed according to user requirements. Users need to provide electrical system diagram.

[Contact Us](#)



Mongolian Explosion-proof Distribution Box Installation Company

Free shipping, arrives in 3+ days Champion Power Equipment Yellow 19.10" x 15.90" x 10.00", Steel Portable Electrical Distribution Box \$433.63 Champion Power Equipment Yellow 19.10" x 15.90" x

[Contact Us](#)



Best Explosion Proof Lighting Distribution Box in

Certified to meet international safety standards like ATEX and IECEx, the Explosion Proof Lighting Distribution Box guarantees safe and reliable power distribution. It

[Contact Us](#)





Explosion-proof Distribution Box

China Explosion-proof Distribution Box catalog of Exd Explosion Prevention Exe Aluminum Alloy Junction Box Explosion-Proof Threading Straight Box Ex Seal Wire Box, Explosion-Proof Type a

[Contact Us](#)



Explosion Proof Distribution Box & Electrical Enclosures

Durable Hexlon Explosion Proof Distribution Boxes and Electrical Enclosures, IECEx and ATEX certified for Zone 1 and Zone 2.

[Contact Us](#)

BXM (D)51 Series Explosion proof Distribution Boxes

BXM (D)51 Explosion proof Distribution Boxes Explosion protection to -CENELEC -IEC -NEC Can be used in Zone 1 and Zone 2 Zone 21 and Zone 22 Class I, Zone

[Contact Us](#)



Explosion-proof illumination (power) distribution box (power)

3. Adopting the patented technology of the combined explosion-proof distribution box independently developed, the modular design and combination of the distribution box makes the whole distribution

[Contact Us](#)

Inner Mongolia Jiutai New Materials Co., Ltd



Explosion-proof

For the explosion-proof operation column, distribution box and straight-through wiring box project of Inner Mongolia Jiutai New Materials Co., LTD., our company provided corresponding

[Contact Us](#)



IP65 / IP67 Sealing Design

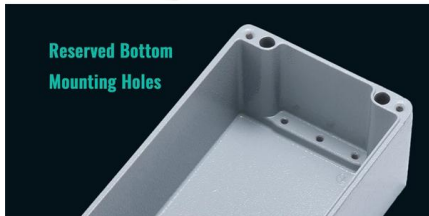

Reserved Bottom Mounting Holes

Explosion-proof and anti-corrosion power (lighting) distribution box

Executive standards: GB 3836.1, GB 3836.2, GB 3836.3, GB12476.1, GB12476.5, IEC60079-0, 1EC60079-1, IEC60079-7 Explosion-proof mark: Ex de IIC T4/T5/T6 Gb/Ex tD A21 IP66 T130°C

[Contact Us](#)

Energy Distribution

BARTEC's Ex zone 1 Power Handling Systems are designed for extended maintenance and remote operated installations. They include fully modular low-



[Contact Us](#)



Explosion Proof Lighting Distribution Box

Certified to meet international safety standards like ATEX and IECEx, the Explosion Proof Lighting Distribution Box guarantees safe and reliable power distribution. It

[Contact Us](#)



Songbei Explosion-Proof Anti-Corrosion Lighting Power Distribution Box

The Songbei Explosion-Proof Anti-Corrosion Lighting Power Distribution Box BXM (D)8050-6K is a state-of-the-art electrical distribution solution, specifically designed for hazardous and explosive

[Contact Us](#)



Contact Us

For datasheets, pricing, or custom fiber access solutions, please visit:
<https://frindel.es>