

# Lighting Distribution Box Circuit Breaker Model





## Lighting Distribution Box Circuit Breaker Model



### The Complete Guide to Distribution Box: Installation, Types & More

Home distribution boxes typically handle single-phase power supplies and contain 6 to 24 circuits. They include standard circuit breakers for lighting, outlets, and major appliances like water

[Contact Us](#)

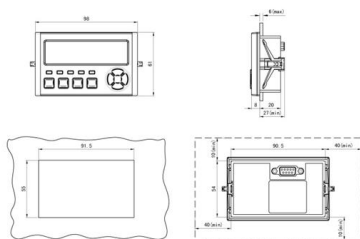

### Electrical distribution box home lighting box 20-22 ways surface

Product Name: Distribution box Product Type: 22-24 Ways Product color: Elegant white Dimensions: 19.5\*18\*7 cm Scope: a variety of family style Product quality: no deformation, no

### Distribution Boards & Consumer Units

Mini Center Compact is a reliable range of distribution boards allowing maximum flexibility, offering wide choice of incomers: Switch Disconnector, MCCB, MCB, RCCB, RCD or Direct Cable Connection.

[Contact Us](#)



### DB BOX(Electrical Distribution Box): Everything You

Wiring: Next, the electrical cables will be connected to the incoming power source (like the main distribution panel) and the outgoing circuits. Circuit

[Contact Us](#)



### Distribution Box and Selection Guide

It contains a number of safety mechanisms, including fuses and circuit breakers, which aid in preventing overloads and short circuits. This

[Contact Us](#)



### Electrical Distribution Board Wiring Diagram , EdrawMax

What is Electrical Distribution Board? A distribution board (also known as Panel Board, breaker panel, or electric panel) is a component of an

[Contact Us](#)



### POWER PRODUCT Panelboards

Introduction distribution technology. The "P Series" line of panelboards offers a stepped approachable panelboard family. Engineered specifically to provide maximum flexibility, the new designs simplify

[Contact Us](#)

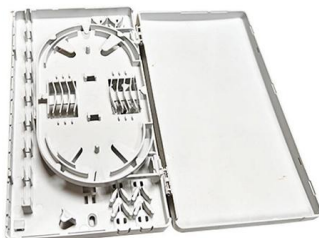



## High-Quality Electrical Lighting Distribution Boxes Explained

These boxes serve as central hubs for managing multiple lighting circuits, allowing for efficient power distribution and control. High-quality distribution boxes, like the FPD-85/3L model, offer several key

[Contact Us](#)



## Circuit Breaker Distribution Box SHEN Series

The Circuit Breaker Distribution Box is a modular, waterproof enclosure designed for street lighting control systems, offering unrivalled convenience and protection for

[Contact Us](#)

## Decoding the Breaker Box Schematic: A

Learn about the breaker box schematic and how it is used to diagram the electrical connections and components in a circuit breaker panel.

[Contact Us](#)

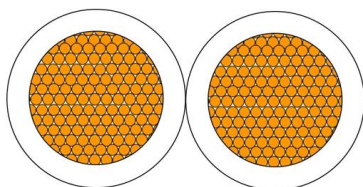
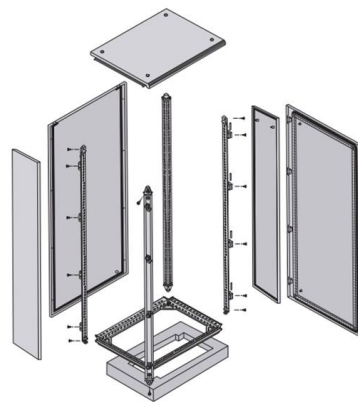

PRODUCT MODEL: RVS  
CONDUCTOR MATERIAL: Copper  
RATED VOLTAGE: 450/750V

## Power Distribution Boxes Explained Simply

Key Takeaways A power distribution box (also called PDU or distro) directs electricity from a main source to multiple circuits. It acts like a hub or traffic

[Contact Us](#)

## Electrical Distribution CAD files , Schneider



Download Schneider Electric Electrical Distribution CAD files in over 40 different file formats

[Contact Us](#)



### Distribution Boxes: Types and Functions

A distribution boxes acts as the load center and main distributor of electrical power within a building. Also called a distribution board, panel board,

[Contact Us](#)



### Distribution Boxes Types - The Complete Guide

The power distribution boxes deliver electricity from the main electrical main to other circuits. Several distribution boxes are designed for specific use in

[Contact Us](#)

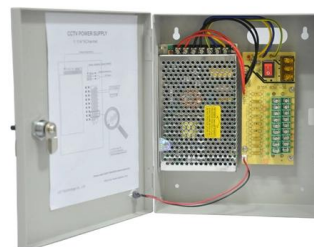

### Distribution Box: Types and Functions , Axis-Electricals

A distribution box houses all the contact breakers, earth leakage units, doorbells, and timers. The electrical power supply comes from the network to the building

[Contact Us](#)





## Distribution Box and Selection Guide

Different settings have distinct electrical requirements: Residential: Homes typically require single-phase power and a Distribution Box with fewer

[Contact Us](#)



### Electrical distribution box home lighting box 16-18 ways

Product Name: Distribution box Product Type: 16-18Ways Product color: Elegant white Dimensions: 21\*39.5\*9 cm Scope: a variety of family style Product quality:

[Contact Us](#)

## Main Lighting Distribution Board (LDB)

A lighting distribution board is a type of electrical panel that is used to distribute power to lights and other loads in a building. The main difference between a

[Contact Us](#)



### Small Waterproof Distribution Box

Small Waterproof Distribution Box - 2P PV-Special Waterproof Box (with Circuit Breaker) Solar Combiner Box DC500V Lightning Prot (4)

[Contact Us](#)



## Understanding Electrical DB Boxes: Your Ultimate Guide to Safety

Its primary function is to distribute electrical power from a single source to various circuits within a building. By housing circuit breakers or fuses, the DB box acts as the central hub for managing

[Contact Us](#)



## Breaker Box Parts Diagram and Components Explained

The breaker box consists of several key components that help manage and distribute electricity throughout your home. Begin by recognizing the main parts that make up the system: the main

[Contact Us](#)

## DISTRIBUTION BOARDS CATALOG

BAHRA Circuit Breakers Enclosure are powered with the best selection of international proven quality of breakers by BAHRA to provide reliable circuit protection against overload and short circuits.

[Contact Us](#)



## Distribution Box Guide: Types, Components & Solutions

From traditional main circuit breaker panels to innovative smart distribution boxes, the evolution of this essential equipment has significantly

[Contact Us](#)



### Single Line Diagram for Lighting DB

This document contains an electrical diagram showing the distribution of power from a main distribution panel board to various electrical circuits through multiple

[Contact Us](#)



### Electrical Single Line Diagram of DB , AutoCAD Drawing

This AutoCAD DWG file includes a complete Single Line Diagram (SLD) of a Distribution Board, showing circuit breakers, wiring connections, and load

[Contact Us](#)

## Contact Us

---

For datasheets, pricing, or custom fiber access solutions, please visit:  
<https://frindel.es>