

Hungarian Flame-Retardant Fireproof Cable Trays





Hungarian Flame-Retardant Fireproof Cable Trays



HAMICABLE - Tray flame retardant cable

Tray flame retardant cable 0.6/1kV TFR-CV
0.6/1kV TFR-CVV 0.6/1kV TFR-CVVS 0.6/1kV TFR-
GV 6/10kV TFR-CV 0.6/1kV TFR-CV Range of
application

[Contact Us](#)

Cable Tray Covering & Fire Protection

FireResistant Solutions provides cable tray covering and fire-protection systems designed to safeguard electrical and data infrastructure in commercial and multifamily buildings. These systems prevent fire



[Contact Us](#)

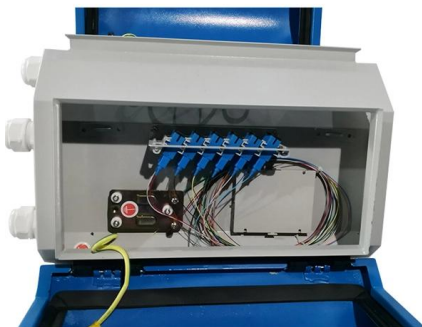

Instrument FireMaster® fire protection cable tray

The FireMaster instrument control cable tray system is Factory Mutual Approved for 30 minute hydrocarbon fire protection of instrument control cable trays in accordance with ASTM E1725-95

[Contact Us](#)

Fire-Resistant Cable Support Systems

Meka Pro regularly tests the fire resistance of its products to ensure high-quality and safe cable management systems. The products are tested extensively and using

[Contact Us](#)



Cable Tray Fire Incident: Your Safety Questions Answered

Learn how cable tray fires start, real case studies, and proven prevention tactics. Protect your site from Cable Tray Fire Incident.

[Contact Us](#)

Advanced Fire Resistant Cable Tray , Maximum Heat

Top-quality fire resistant cable tray with N1 fire rating, 5-12 mm fireproof core, superior heat insulation, flame protection, and 60-min fire resistance.

[Contact Us](#)

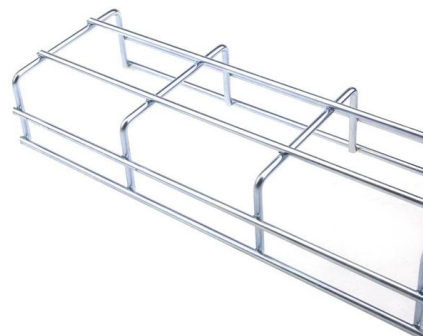

Fire Rated Cable Encasements: Invicta Durasteel

Our 4-hour fire rated cable encasements provide comprehensive fire and blast protection, shielding cables from fire and containing high voltage cable fires

[Contact Us](#)



HENSOMASTIK® and HENSOTHERM® fire protection bandages for cables and cable support systems (cable trays) can inhibit or completely prevent the development of cable fires and the burning of cable

[Contact Us](#)



Fireproof Cable Tray Enclosures: Keep Cabling Systems

Sinisi Solutions works with major utilities and clients to design cable enclosures that protect critical cabling and cable tray setups from heat and fire, and blasts. Sinisi

[Contact Us](#)

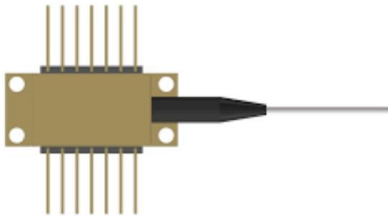

Instrument FireMaster® fire protection cable tray

The FireMaster® cable tray wrap system provides 30 minutes hydrocarbon fire protection to cable trays carrying control cable wiring. The FireMaster® cable tray wrap consists of FireMaster® Marine Plus

[Contact Us](#)

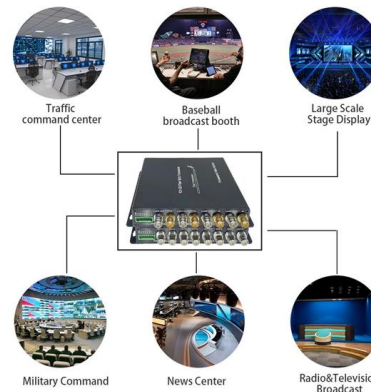

Fireproof Cable Trays Acceptance: Standards for Safety

Fireproof cable trays play a crucial role in modern electrical systems. They provide robust support for cables while ensuring fire safety in extreme

[Contact Us](#)





Trunking and cable trays

Our range of trunking and cable trays products are ideal fire protection solutions for electrical services passing between walls, floors and ceilings.

[Contact Us](#)



FIRE RESISTANT PROOF CABLE TRAY, DIN STANDARD E90

Cablofil fire resistant and fire proof cable trays are increasingly specified in the construction, power, oil, gas, petrochem, rail and utilities industries. Cablofil cable tray has been successfully tested and

[Contact Us](#)



Basor Electric

These standards define the test conditions to verify that the system, made up of fire resistant trays, supports, accessories and cables, maintains the power supply for

[Contact Us](#)

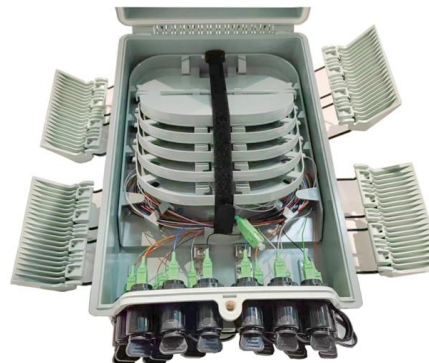

Fire-Resistant Cable Trays in High-Risk Environments

These composite trays are manufactured using flame-retardant materials that prevent fires from spreading. They offer

[Contact Us](#)



Fireproof Channel Cable Tray System

Fireproof coating is an efficient protection product for steel structures. It is composed of polymer synthetic resin as film-forming material, flame retardant, blowing

[Contact Us](#)



Fireproof Channel Cable Tray System

External fire retardant coating layer spraying requirements are uniform, and smooth, with no obvious color difference. The inner layer is equipped with a fire-proof

[Contact Us](#)

Fire resistant cable tray , Hermi-solutions

Cable trays are intended for the construction of fire-resistant cable paths with surface cable laying. Cable paths are constructed as standard or lightweight cable paths.

[Contact Us](#)



Fire stop section of the cable tray and cable management NEMA

The resulting barrier retards the transmission of smoke, fire, and toxic gases from spreading between adjacent rooms and floors for the rated time period. The following charts give the number of 3M

[Contact Us](#)

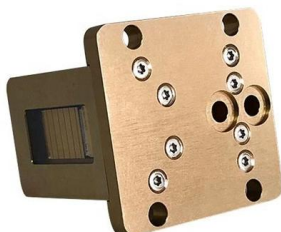

Fire protection for cables & cable trays ,

The mostly combustible cable sheaths and insulation allow a fire to spread along the cable at rapid speed. Our tested solutions for cable fire protection can delay the

[Contact Us](#)



What are the fireproof characteristics of cable trays?

Only the fire-proof and flame-retardant principle of cables and fire-resistant coatings are on fire. At present, fire-resistant cable racks are mainly

[Contact Us](#)



Fire Rated Cable Tray, Heavy-Duty Cable Tray Manufacturer

Fire Rated Cable Trays that are crafted from premium materials like stainless steel, galvanized steel, tempered glass, and fire-resistant polyester fiberglass. Each tray is coated with a specialized fire

[Contact Us](#)



UNIFRAX Fyrewrap fireproof Coating for Cables, Cable

UNIFRAX Fyrewrap "Fyrewrap Cable Insulation®" is a thin and flexible insulation material designed to provide fire protection for cable trays and circuits. Its

[Contact Us](#)





Fire Resistance Testing of Cable Trays: Key Standards

Are Your Cable Trays Fireproof? Here's How to Find Out When a fire breaks out, the last thing you want is your cable trays fueling the flames. But how

[Contact Us](#)



Technical Guidelines for Cable Tray Installation and

Fire-resistant trays must be made from non-combustible or flame-retardant materials such as: Galvanized steel, Stainless steel, Fire-resistant coated trays, Flame

[Contact Us](#)



Fire Safety Considerations for Cable Trays: Protecting

Learn about essential fire safety measures for cable trays to safeguard your electrical infrastructure. Discover expert guidance and solutions

[Contact Us](#)



Contact Us

For datasheets, pricing, or custom fiber access solutions, please visit:
<https://frindel.es>