

# **How to set up protection for distribution boxes**





## Overview

---

Include protection devices like breakers, fuses, and surge protectors—each circuit should have its own protection. You must make safety your top priority when working with low voltage distribution boxes. Choose the right box based on environment (indoor/outdoor), load capacity, and durability. In modern electrical systems, cable distribution boxes (also known as electrical distribution boxes or distribution boxes) play a crucial role as the key hub for managing, distributing, and protecting circuits. A well-chosen and properly installed distribution box can prevent electrical hazards, reduce downtime, and ensure your electrical system operates smoothly for years to come.



## How to set up protection for distribution boxes

---



### Analysis of the protection level test standard for distribution boxes

Distribution boxes protect our electrical systems like bodyguards shield VIPs. When they fail, everything goes dark. Today, we'll explore how international standards translate into practical

[Contact Us](#)

### Understanding Distribution Boxes: A Comprehensive Guide

Learn what a distribution box is, its types, and how to choose the right one for your project. Includes clear examples and expert tips.

[Contact Us](#)



### Installation Standards and Safety Precautions for Distribution Boxes

10. Distribution boxes, switch boxes should be installed in dry, ventilated and room temperature places; shall not be installed in the role of serious damage to the gas, smoke, vapour,

[Contact Us](#)

### Requirements And Specifications For Installation Of

A leakage protector should be installed in the distribution box to provide additional safety protection. Installation requirements in special

[Contact Us](#)



### **Nagaland News, India News, Northeast News**

The Morung Express brings the Latest News, Top Breaking headlines on Politics and Current Affairs in Nagaland India and around the World, Naglaand News, Naga

[Contact Us](#)

### **The installation requirements for the distribution box**

Reliable cable distribution boxes ensure safe, efficient power management for residential, commercial, and industrial systems. Learn

[Contact Us](#)



### **Distribution Box Guide: Types, Components & Solutions**

In solar and wind energy setups, distribution boxes manage and distribute the electricity throughout the building or facility. They frequently include

[Contact Us](#)

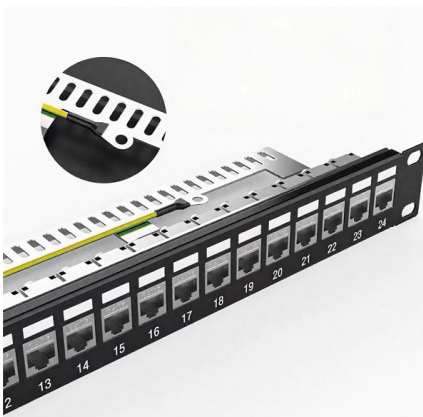

### **DB BOX(Electrical Distribution Box):**



## Everything You

Learn everything you need to know about the Electrical Distribution Box (DB Box). Explore types, materials, installation tips, etc.

[Contact Us](#)



### Installation Standards and Safety Precautions for Distribution Boxes

Switch box shall be distributed by the final sub-distribution box. 2. The power distribution box and switch box must be rainproof and dustproof. 3. When the construction site stops working for

[Contact Us](#)

### Distribution Boxes Explained: Types, Functions, and

Learn about distribution boxes, their types, functions, and safety features to ensure efficient and secure electrical power distribution in any building.

[Contact Us](#)



### 1.An Ultimate Guide for Metal Distribution Boxes

1) Metal Distribution Boxes Constructed from steel, aluminum, or cast iron, metal distribution boxes are highly durable and resistant to mechanical damage. Ideal

[Contact Us](#)

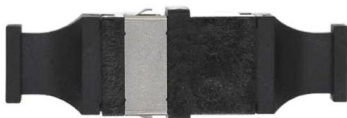



## Requirements And Specifications For Installation Of

The installation of explosion-proof distribution boxes should follow specific explosion-proof grades and material requirements to ensure their safety

[Contact Us](#)



## Key Material Requirements for Distribution Box

Learn the key material requirements for distribution box, Discover how the right materials ensure long-lasting performance and safety.

[Contact Us](#)



## How to Install a Distribution Box--A Comprehensive

Usually, electrical enclosures are used to protect the internal electronic components of distribution boxes from water, dust and damage. When

[Contact Us](#)



## An Ultimate Guide for Metal Distribution Boxes

Distribution boxes are an essential part of every home or building's electrical system. These enclosures house wiring connections for various applications such as

[Contact Us](#)





## Design requirements and standards for low voltage

When you use surge protective devices (SPDs), you should set them up in stages. Start with an SPD at the main distribution board, then add more

[Contact Us](#)



## Installation requirements for distribution boxes

Distribution boxes shall be made of non-combustible materials; open distribution boards may be installed in production places and offices with low electric shock risk; enclosed cabinets shall

[Contact Us](#)

## Electrical Power Distribution Box: A General Installation

A Electrical Power Distribution Box is a critical hub in any electrical installation, organizing and protecting power for multiple circuits. This article

[Contact Us](#)

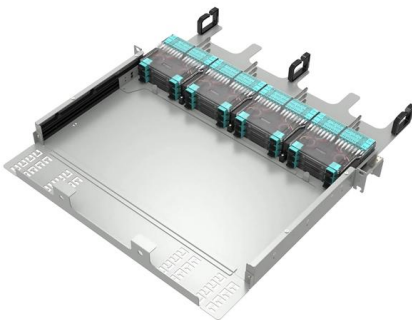

## Safety requirements of distribution box

The distribution box has the characteristics of small size, simple installation, special technical performance, fixed location, unique configuration function, not limited by

[Contact Us](#)



## Understanding Distribution Boxes:A Comprehensive Guide

A distribution boxes is an essential device that manages the safe and efficient flow of electrical power throughout different areas of a building or facility.

[Contact Us](#)



## Power Distribution Boxes Explained Simply

Discover the essentials of a Power Distribution Box--how it works, key types, benefits, and tips to ensure safe, efficient electrical power management.

[Contact Us](#)

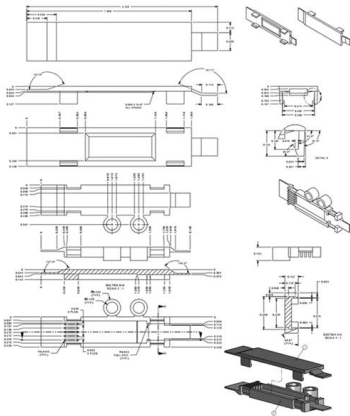

## How to Install a Distribution Box--A Comprehensive

Whether you are an electrical contractor or a construction brigade, knowing how to properly and safely install distribution boxes is the basis of

[Contact Us](#)



## How to Choose a House Distribution Box , CHINT global

A well-chosen distribution box ensures the safety and efficiency of your household electrical system. This article guides you through selecting a

[Contact Us](#)

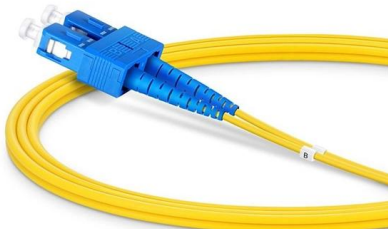



## What Are Distribution Boxes and Their Functions in

Understand the role of distribution boxes in fiber optics. Learn about their components, types, and functions in protecting and managing fiber optic

[Contact Us](#)

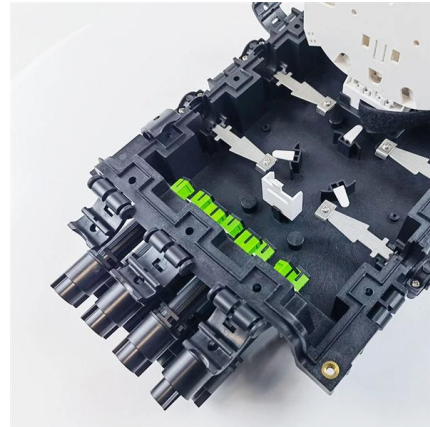

## The Complete Guide to Distribution Box: Installation, Types & More

Enhanced safety features in premium distribution boxes include improved arc fault protection, better insulation systems, and more reliable protective devices. These features reduce

[Contact Us](#)

## Contact Us

---

For datasheets, pricing, or custom fiber access solutions, please visit:  
<https://frindel.es>