

How to calculate the quota for distribution boxes





Overview

This calculation is carried out if you have the source of supply for a requested material determined by the system. Calculating the Quota Rating The system assigns a quota rating to each source of supply. Quota Arrangement is a strategic approach to ensure fair and efficient vendor allocation, helping teams meet objectives without overburdening any single unit. Whether you're managing sales teams, production lines, or project workloads, a well-structured quota system can enhance productivity and. Quota rating can be calculated by the following formula – $Quota\ rating = (Quota\ Allocated\ Quantity + Quota\ Base\ Quantity) / Quota$ Where the Quota Allocated Quantity is the total quantity from all orders that are procured from a particular source. com | Global MAX Shipping AI powers instant, accurate international shipping quotes for ocean containers (FCL), LCL, and air cargo—in under 30 seconds, free and without registration. Air freight pricing is usually based on chargeable weight, which is the higher of: Your quote is then built from the chargeable weight plus common cost components such as fuel, security, terminal handling, and (when applicable) pickup/delivery and customs.



How to calculate the quota for distribution boxes

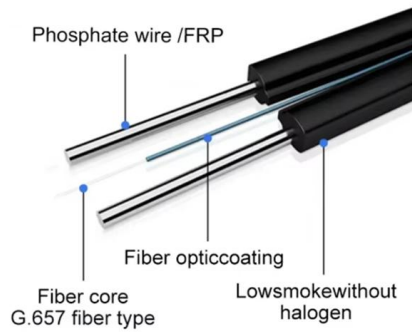

What is a Distribution Box? - A Comprehensive Guide

A distribution box organizes and controls power flow, ensuring safety and efficiency in electrical systems.

[Contact Us](#)

Splitting Quota Arrangement

The system splits the requirements according to the sequence that is defined by the quota, that is, the vendor with the highest quota is selected first. The sequence defined by the quotas can be overruled

[Contact Us](#)



ITPro Today, Network Computing, IoT World Today combine

ITPro Today, Network Computing and IoT World Today have combined with TechTarget . The page you are looking for may no longer exist.

[Contact Us](#)



Flow Repartition in Distribution Boxes

Distribution Box Calculation of Flow Repartition
12 f Distribution Box & Flow repartition I. Quick explanation on pipe flow The pipe Max speed in the is full

[Contact Us](#)



How to choose a distribution box of the right size for a project based

Don't be like younger me - measure twice and install once! Calculating Your Total Load Current: A Practical Walkthrough This is where the rubber meets the road. When I size a distribution box for a

[Contact Us](#)

SAP SD

Quota arrangement divides the total requirement of a material among certain sources of supply i.e. vendors. Quota arrangement can be created by following the steps

[Contact Us](#)

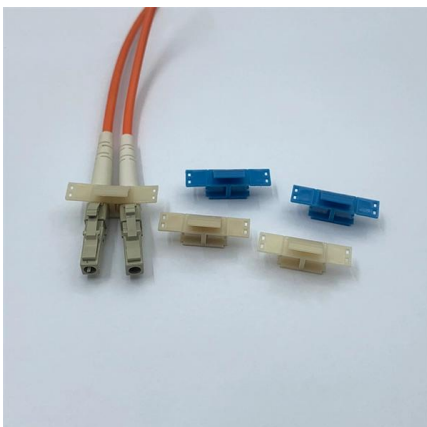

Distribution Boxes Explained: Types, Functions, and

Learn about distribution boxes, their types, functions, and safety features to ensure efficient and secure electrical power distribution in any building.

[Contact Us](#)

How to Choose the Right Distribution Box?



Find out how to choose the right distribution box for your needs! Learn about sizing, safety standards, essential features, and all factors.

[Contact Us](#)

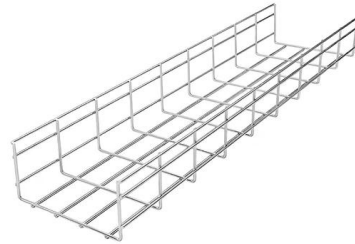

Understanding Distribution Boxes:A Comprehensive Guide

A distribution boxes is an essential device that manages the safe and efficient flow of electrical power throughout different areas of a building or facility.

[Contact Us](#)

Determining the Source Under a Quota Arrangement

According to the formula, the following applies: The higher the quota, the lower the quota rating and the higher the likelihood that the relevant source will be determined as the valid source.

[Contact Us](#)

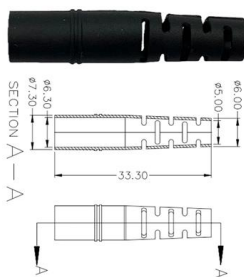

Quota sampling. Everything you need to know

Quota sampling is one of the most common sampling methods in market research. Mastering it will help you to easily implement surveys without help. Today we tell

[Contact Us](#)



SAP MM Quota Arrangement Guide , PDF

It outlines the calculation of quota ratings and the necessary settings in the material master before creating a quota arrangement. Additionally, it provides a step-by

[Contact Us](#)



Calculate Air Freight Costs Online

Get quick air freight quotes. Calculate costs, compare options, and choose iContainers for efficient global air shipping solutions.

[Contact Us](#)

How to Analyze Your Quota Distributions

Discover effective strategies to analyze quota distributions & enhance sales performance. Gain insights for optimizing your team's success. Learn more!

[Contact Us](#)

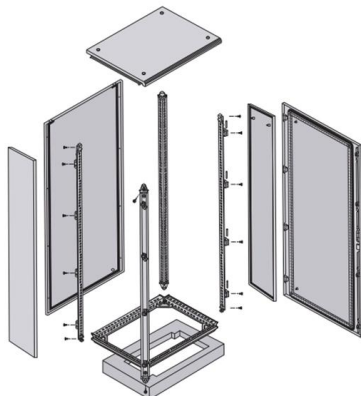

Quota Distribution Calculator

Enter the total quota, period, and your pipeline coverage target. Pick a method: Hybrid for stability, Weighted for signal-driven splits, or Equal for quick baselines.

[Contact Us](#)

How to Calculate How Many Boxes Will Fit



in a Container

Planning to ship goods and wondering, "How many boxes can I actually fit into this container?" It's not as simple as stacking until the doors won't

[Contact Us](#)

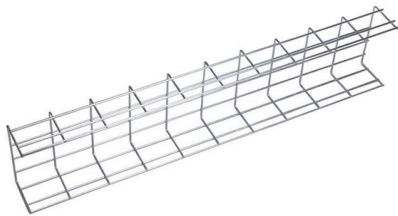

How Do You Calculate How Many Items Fit in a

Volume Calculation: Calculate the volume of your items and compare it with the volume of the box to estimate how much filler material is needed. This calculation

[Contact Us](#)

Understanding Distribution Boxes: A Comprehensive Guide

A distribution box, also known as a power distribution box or electrical distribution box, is used to distribute electrical power safely to multiple

[Contact Us](#)

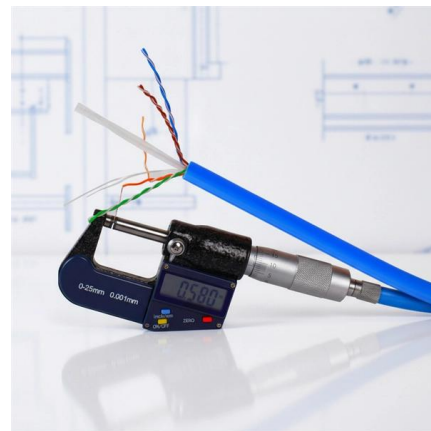

directory-list-2.4.txt/directory-list-2.4.txt at main

Customer stories Events & webinars Ebooks & reports Business insights GitHub Skills

[Contact Us](#)



Important points about SAP S/4 HANA Quota

Quota arrangement usage is mandatory in Purchasing or MRP2 view of Material Master. If it is not maintained, Quota arrangement won't work during

[Contact Us](#)

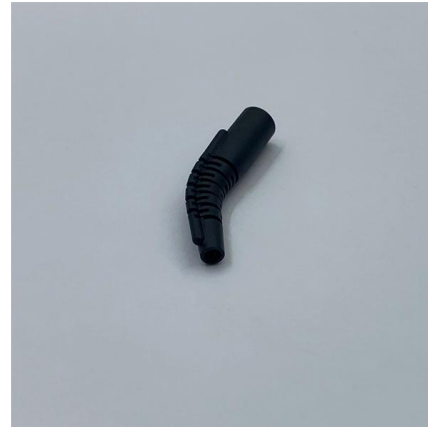

Freight Shipping Calculator , Instantly Calculate Shipping Costs with

Shipping AI Freight-Calculator , Global MAX Shipping AI powers instant, accurate international shipping quotes for ocean containers

[Contact Us](#)



Using Quota Arrangements in SAP - Managing Supplier

Begin by defining your quota arrangement types and selecting applicable suppliers. You'll configure parameters such as the effective dates, the

[Contact Us](#)



How to Calculate the Size and Number of Circuits for a Distribution Box

Okay, let's talk distribution boxes. You know that metal cabinet packed with switches and wires you see in basements? Yeah, that's the heart of your electrical system. Getting its sizing right isn't just about

[Contact Us](#)





How to Set Up Quota Arrangement in SAP - A Step-by-Step Guide

Quota Arrangement is a strategic approach to ensure fair and efficient vendor allocation, helping teams meet objectives without overburdening any single unit. Whether you're managing

[Contact Us](#)



What Is Quota Sampling? , Definition & Examples

Quota sampling can be helpful for getting a broad picture of attitudes, behaviors, or circumstances, such as understanding the range of concerns facing respondents about an issue.

[Contact Us](#)

What Is a Distribution Box? (2026 Guide) , SepticTankHub

A distribution box splits septic effluent evenly across your drain field. Learn how d-boxes work, what failure looks like, and what replacement costs in 2026.

[Contact Us](#)



Contact Us

For datasheets, pricing, or custom fiber access solutions, please visit:
<https://frindel.es>