

How much does a secondary distribution box cost in Brazil





How much does a secondary distribution box cost in Brazil



The distribution network in Brazil

Learn about the distribution market in Brazil. Find out information on the evolution of the retail sector in Brazil and the retail organisations in charge.

[Contact Us](#)

6 Strategies to Beat Brazil Supply Chain Complexities , BCG

By increasing the density of distribution points, they are able to contain secondary transportation costs. Yet even where scale is possible, it's not necessarily beneficial.

[Contact Us](#)



Brazil

Discusses distribution network from how products enter to final destination, including reliability of distribution systems, distribution centers, ports, etc.

[Contact Us](#)



Distribution Box Replacement Cost Guide - One and Done Prep

Typical cost ranges for replacing a distribution box or service panel in the United States vary widely based on panel size, amperage, labor, and whether a full service upgrade is needed.



The Complete Guide to Product Distribution in Brazil

In this article, we will present you with a complete guide to product distribution in Brazil. This article will be divided into three major sections, each representing a key step in establishing a product

[Contact Us](#)

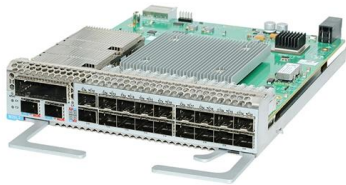

Distribution Box Replacement Cost Guide 2026

Overview Of Costs Cost ranges account for panel amperage, location, and whether a full upgrade or repair is needed. A typical home replacement for a 100-125A indoor panel runs about

[Contact Us](#)

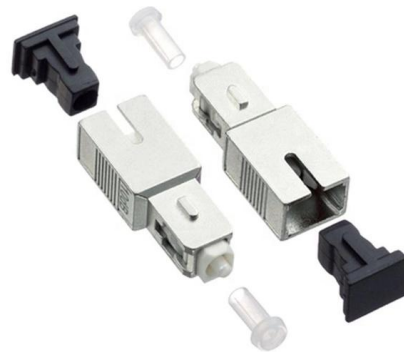

How much does septic distribution box replacement cost?

Septic distribution box (D-box) replacement costs \$600 to \$2,000 on average. Costs vary based on the materials used, local labor rates, and

[Contact Us](#)





Distribution Box in Brazil

Find listing of companies trading Distribution Box in Brazil. Join the list of leading Brazil Distribution Box, manufacturers, suppliers, exporters & wholesalers offering wide spectrum of Distribution Box at

[Contact Us](#)

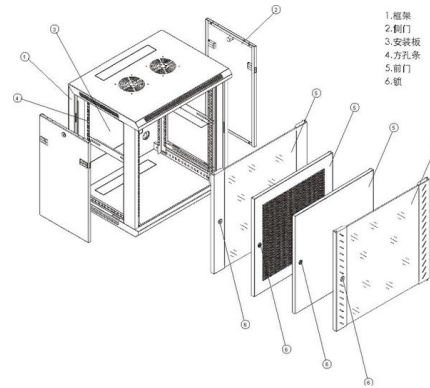

Brazil PV Combiner Box Prices: Trends, Analysis, and Buyer Insights

Wondering why Brazil's PV combiner box prices vary so much? This guide breaks down market trends, cost factors, and smart purchasing strategies for solar professionals. Discover how to balance quality

[Contact Us](#)

Brazil Electric Transmission and Distribution Equipment

The future of the electric transmission and distribution equipment market in Brazil looks promising with opportunities in the power utilities, residential, commercial, and industrial sectors.

[Contact Us](#)



How Much Is A Distribution Box A Complete Buyers Guide

The Price Landscape: Breaking Down the Costs When you start looking for a distribution box, you'll quickly realize the price range is wider than a highway. You might find a small plastic unit for the

[Contact Us](#)

The Meaning and Function of Primary, Secondary, and Tertiary



Follows the principle of "one machine, one switch, one RCD, one box, one lock," ensuring no single switch controls multiple devices. This explanation aims to clarify the roles and functions of

[Contact Us](#)



ITPro Today, Network Computing, IoT World Today combine

ITPro Today, Network Computing and IoT World Today have combined with TechTarget . The page you are looking for may no longer exist.

[Contact Us](#)



cs-178-project/imdb.vocab at main · apmalani/cs-178-project

Contribute to apmalani/cs-178-project development by creating an account on GitHub.

[Contact Us](#)

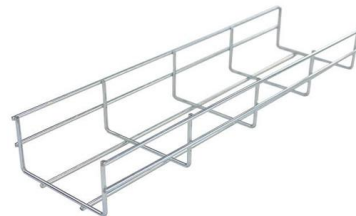

Distribution Box Cost Guide 2024: Comprehensive Pricing, Features

Discover complete distribution box cost analysis including pricing factors, advanced features, safety benefits, and smart technology innovations. Get expert insights on ROI, installation costs, and long

[Contact Us](#)





Brazil Distribution Box Market Scalability and Strategic Outlook

Optimize pricing and cost structures through supply chain efficiencies and localized manufacturing, enabling competitive pricing strategies that cater to both large-scale projects and

[Contact Us](#)

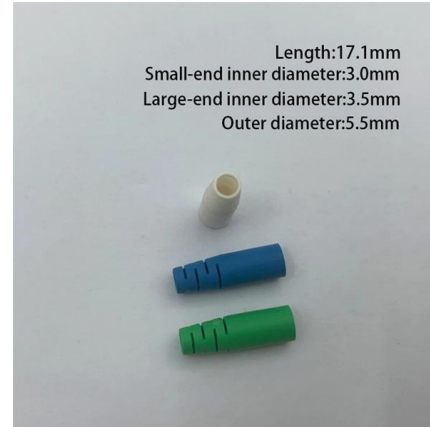

The Brazil Residential Distribution Box Market

The Brazil residential distribution box market is a vital segment within the broader electrical equipment industry, serving as a critical component in

[Contact Us](#)

U.S. News: Latest Breaking Stories and Video on

Get the latest news headlines and top stories from NBCNews . Find videos and news articles on the latest stories in the US.

[Contact Us](#)

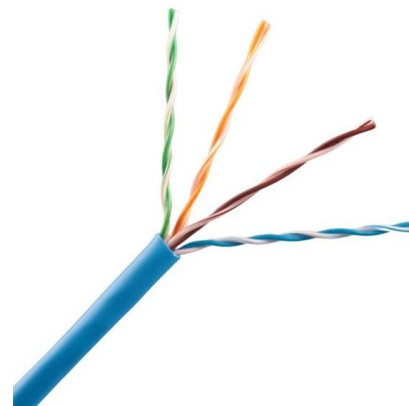

Top Content on LinkedIn

Explore top LinkedIn content from members on a range of professional topics.

[Contact Us](#)



WORLD WIDE WEB JOURNAL Home

O'Reilly & Associates, Inc. 103A Morris St.
Sebastopol, CA United States

[Contact Us](#)

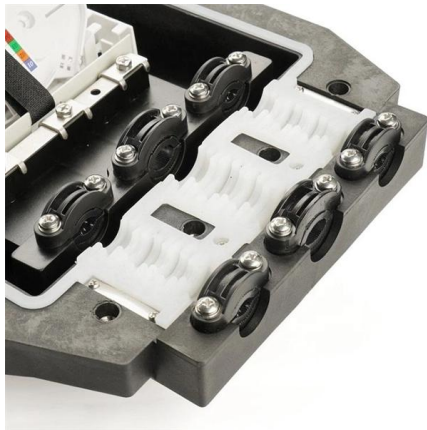

How Much Is A Distribution Box A Complete Buyers Guide

When you start looking for a distribution box, you'll quickly realize the price range is wider than a highway. You might find a small plastic unit for the price of a fancy dinner, or an industrial-grade

[Contact Us](#)

Brazil Import Duties 2026: Full Cost Breakdown + Tax

How much does it really cost to import to Brazil? Full breakdown of II, IPI, ICMS and the new CBS/IBS under the 2026 tax reform -- with examples.

[Contact Us](#)



Distribution Box Replacement Cost Guide - Design Transition Studio

Distribution Box Replacement Cost Guide January 24, 2026 Buyers typically pay a broad range for replacing a distribution box, driven by box size, amperage, wiring runs, and local labor rates. This

[Contact Us](#)





Comprehensive Guide to Septic Tank Distribution Box Costs

Discover costs, factors, and tips for replacing your septic tank distribution box to ensure a reliable wastewater system.

[Contact Us](#)



Establish a Distribution Channel in Brazil in less than 45 days

This is an extensive guide to demonstrate how your company, in as little as 45 days, can start selling your products or services through a Brazilian distribution channel. At any given time there are

[Contact Us](#)

The Brazilian Energy Distribution System

The Brazilian energy distribution system represents a critical aspect of the country's infrastructure. In this article we will present an overview of Brazil's

[Contact Us](#)



Contact Us

For datasheets, pricing, or custom fiber access solutions, please visit:
<https://frindel.es>