

How much does a 10-meter-long pigtail cost

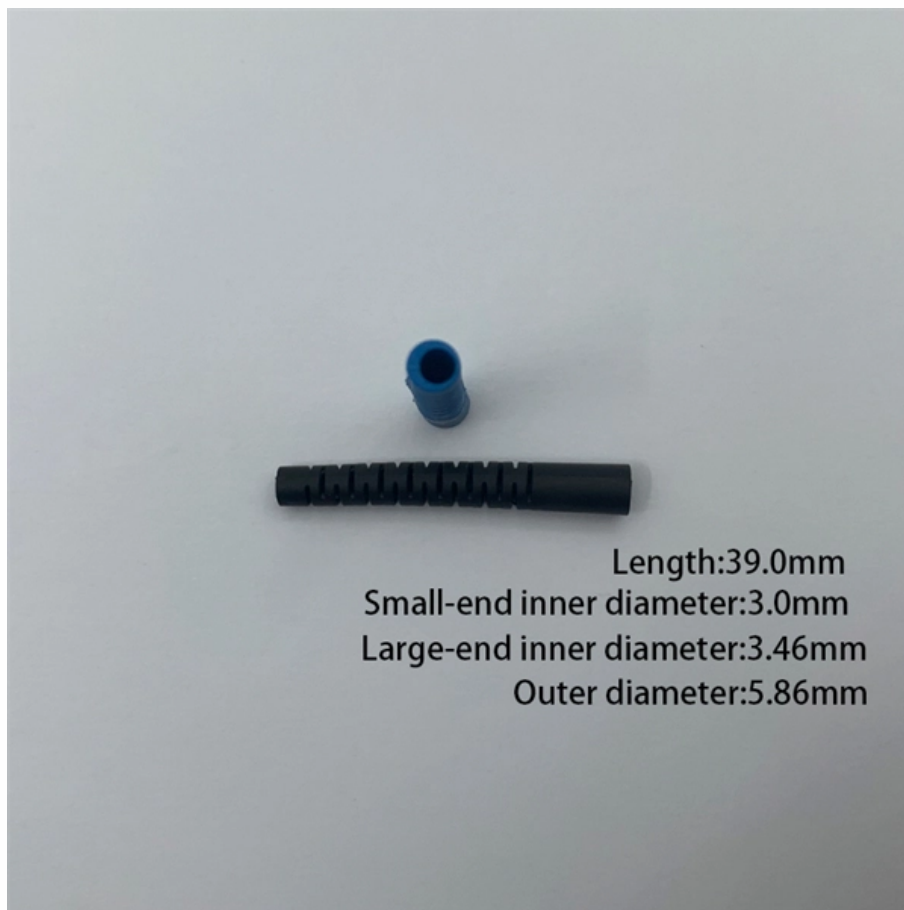



Overview

Purchasing and installing pigtails for aluminum wiring typically runs from a few hundred to several thousand dollars, depending on circuit count, wire gauges, and labor. The main cost drivers are material choices, labor time, and the need for anti-oxidation connectors and proper. A small condo or limited scope may fall on the low end, while a larger house with many outlets and. For a typical mid-sized home, the total project cost often falls within a range of \$800 to \$2,000 for a smaller. If you require pricing for an unlisted length or our premium fast track service, call us on 01702 443810. Learn More Fibre pigtail with SC connector - Multimode 50µ 900µm buffered white 1. What elements should guide the choice of fiber optic cables?

When selecting fiber optic cables, consider environmental rating and type of meter pigtail.



How much does a 10-meter-long pigtail cost

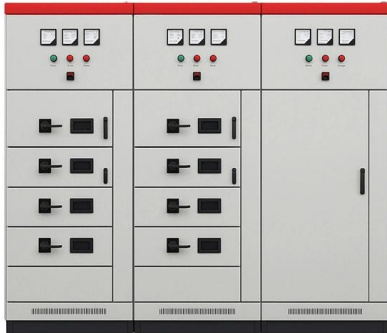

Fibre Optic Pigtails , ST , SC , LC , FC , OM1 , OM2

Buy ST, SC, FC and LC fibre optic pigtails in Singlemode (OS1) or multimode (OM1, OM2, & OM3) at low prices direct from MCL Data Solutions.

[Contact Us](#)

How to Make Pigtail Electrical Wire Connections

How to Make a Pigtail Wire The National Electric Code requires a pigtail wire to be least six inches long. Electricians often cut their own pigtails

[Contact Us](#)



BNMD-RND-IFU-38 Multipurpose Drainage Catheter Pigtail

The Multi-Purpose Drainage Catheter Pigtail is flexible tube made of polyurethane, intended for percutaneous introduction into two or more abdominothoracic anatomies (nephrostomy, biliary,

[Contact Us](#)

Discover Premium Meter Pigtail Solutions for Telecommunications

Discover premium meter pigtails for seamless data flow. Featuring SC/APC, LC, FC connectors, PVC/LSZH jackets, and G652D/G657A fibers. Ideal for FTTH, telecom, and networking. High



FindPigtails , Automotive Connectors

Search the exact automotive plug, pigtail, or OEM connector you need in 30 seconds or less. No confusion, no part hunting, just results. Repair-first mindset, replace

[Contact Us](#)



Strengthen door locks
More durable and aesthetically pleasing

Grounding screw
More aesthetically pleasing and safer

Removable hinges
Make operation more convenient

Sealing strip
Dustproof and waterproof

How Much Does It Cost to Pigtail Aluminum Wiring?

Get a full cost breakdown for pigtailing aluminum wiring. We detail approved methods, necessary materials, and total project variables.

[Contact Us](#)

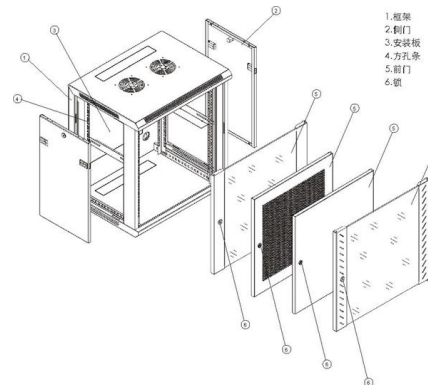

AshwinD24's gists · GitHub

GitHub Gist: star and fork AshwinD24's gists by creating an account on GitHub.

[Contact Us](#)



10 ft. Pigtail (10 Ft Extra Long Wiring Pigtail)



Extend your wiring reach with the FPV-Power 10 Ft. Pigtail. Ideal for longer wiring tasks, this pigtail provides extra length to tackle any job.

[Contact Us](#)



Shop Automotive Pigtails , FindPigtails

Repair any vehicle's wiring connectors with confidence. Easily find automotive pigtail by make, model, year, pin count, or keywords.

[Contact Us](#)

What Is a Pigtail Wire and When Do You Need One?

The practical application of pigtail wiring begins with ensuring the circuit is fully de-energized, which must be confirmed with a voltage meter. To create the splice, the insulation is carefully stripped from the ends

[Contact Us](#)



Ground Pigtails

Insulated Pigtail, 12 AWG Solid Copper Lead stripped 1", Length: 10-1/2". Includes: GSH Ground Screw. Package of 50. *Dottie Part 16102.*

[Contact Us](#)

How To Choose the Correct Pigtail



Getting your temporary power system up and running starts with the right pigtail. As you're setting up your electrical infrastructure, pigtails provide a

[Contact Us](#)

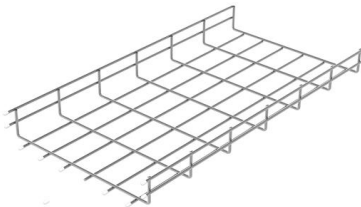

Pigtail - Standard Wire & Cable Co

CONDUCTOR: Soft stranded tinned copper.
CONSTRUCTION: Rope lay, close right-hand lay, extra flexible. USES: Shunt leads, brush leads, magnetic switches, relays, etc

[Contact Us](#)

Amazon : Electrical Pigtail

Discover heavy-duty electrical pigtail cords built to handle demanding power needs. Find options in various lengths and configurations to suit your application.

[Contact Us](#)



The Ultimate Guide to Pigtail Cable Assemblies and

A pigtail cord can be 1 to 5 meters long. Typically, in most cases, the standard length is around 2 meters (6.56 ft) because it has sufficient reach

[Contact Us](#)



Pigtailing Aluminum Wiring: Price and Cost Guide

Cost ranges for pigtailing aluminum wiring reflect typical residential electrical work where aluminum conductors meet copper terminations. The total project often falls in the \$500-\$3,500

[Contact Us](#)



7.5mm Radius



Pigtailing Aluminum Wiring Cost Guide - Adnan Painting and

Overview Of Costs Cost ranges reflect typical residential work to pigtail aluminum wiring to copper for safety and code compliance. Total project ranges and per-unit ranges are provided with

[Contact Us](#)

How to Install a Pigtail Electrical Receptacle

A pigtail is a short conductor, typically six to eight inches long, used to connect a device to the main circuit wires inside the electrical box. The pigtail acts as an intermediary, with one end

[Contact Us](#)

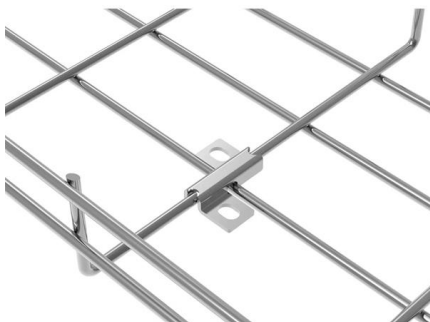

Electrical Pigtail: 6 Steps Wiring Guide for Safe

Learn how to create an electrical pigtail for safe and secure wiring connections. Follow our step-by-step guide and essential tools list.

[Contact Us](#)



Fiber Optic Pigtails for Sale

FS fiber optic pigtails offer a fast way to make fiber optic communication devices in the field by fiber splicing, fully manufactured and tested by industrial standards.

[Contact Us](#)

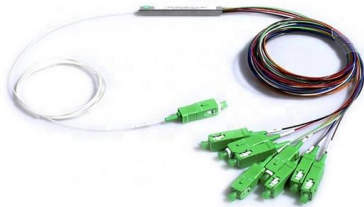

Amazon : Grounding Pigtail

Browse grounding pigtails featuring solid copper wire and green ground screws. Quick installation with reliable electrical bonding for safety.

[Contact Us](#)

Pigtailing Aluminum Wiring Costs and Pricing Guide

Installation time and crew size are major determinants of price for pigtail work. The breakdown below presents typical components and how they contribute to the overall cost.

[Contact Us](#)



Pigtail Aluminum Wiring Cost Guide 2026

Typical cost range to pigtail aluminum wiring in an existing home is approximately \$2,000-\$6,000 for a standard retrofit, depending on the number of outlets and the need for panel or breaker

[Contact Us](#)



Metal Cost Estimator , Material Planning Tool , By Maker

Our advanced Metal Cost Estimator helps you calculate precise material costs for fabrication and metalworking projects. Select from various metal types (steel,

[Contact Us](#)

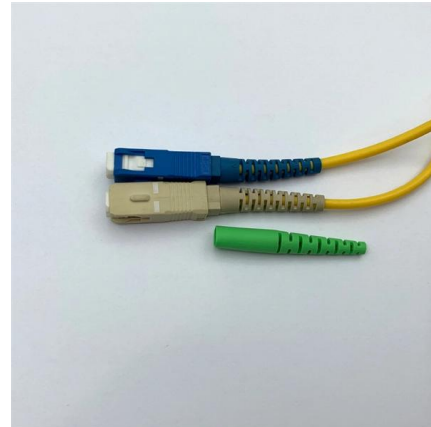

Pigtail Replacement Power Cords , McMaster-Carr

Choose from our selection of pigtail replacement power cords, including power cords, sure-grip power cords, and more. Same and Next Day Delivery.

[Contact Us](#)



IDEAL 12 AWG Solid 10 in. Pigtail with Loop and Ground Screw and

Safe, fast and efficient for cost-effective grounding jobs 12 AWG solid 10 in. pigtail with loop and ground screw and stripped end Thread-forming, hole-finding 10/32 x 3/8 in. ground screw with combination

[Contact Us](#)



Pigtails , McMaster-Carr

Choose from our selection of pigtails, including gauge siphon tubes, power cords, and more. Same and Next Day Delivery.

[Contact Us](#)

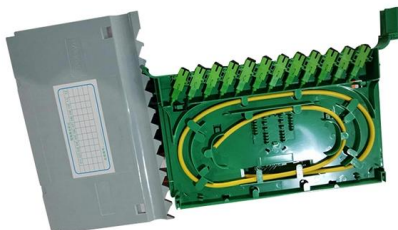



DKURVE SC/APC Pigtail 10Piece SM Fiber Optic Pigtails, Yellow

DKURVE SC/APC Pigtail 10Piece SM Fiber Optic Pigtails, Yellow, 1.5 Meter (Pack of 10) : Amazon : Electronics The SC APC fiber optic pigtail has one end pre-terminated with the SC APC fiber optic

[Contact Us](#)



- IP65/IP55 OUTDOOR CABINET
- OUTDOOR MODULE CABINET
- OUTDOOR ENERGY STORAGE CABINET
- 19 INCH



Pigtail Aluminum Wiring Cost Guide 2026

Overview Of Costs Typical cost range to pigtail aluminum wiring in an existing home is approximately \$2,000-\$6,000 for a standard retrofit, depending on the number of outlets and the

[Contact Us](#)

Contact Us

For datasheets, pricing, or custom fiber access solutions, please visit:
<https://frindel.es>