

# How many circuits require what size distribution box





## Overview

---

Home distribution boxes typically handle single-phase power supplies and contain 6 to 24 circuits. They include standard circuit breakers for lighting, outlets, and major appliances like water heaters and air conditioning units.



## How many circuits require what size distribution box

---



### Understanding Distribution Boxes: Your Guide to Power

Weatherproof Distribution Boxes These serve specific outdoor purposes, with rain, dust, and extreme temperatures sealed shut, protecting any

[Contact Us](#)

### DB BOX(Electrical Distribution Box): Everything You

Wiring: Next, the electrical cables will be connected to the incoming power source (like the main distribution panel) and the outgoing circuits. Circuit

[Contact Us](#)



### How to Choose a House Distribution Box , CHINT global

A well-chosen distribution box ensures the safety and efficiency of your household electrical system. This article guides you through selecting a

[Contact Us](#)



### How Many Electrical Outlets, Circuits, and Wires?

Understanding the required quantities for outlets, circuits, and wiring ensures the electrical system is safe, functional, and compliant with safety standards. These standards dictate

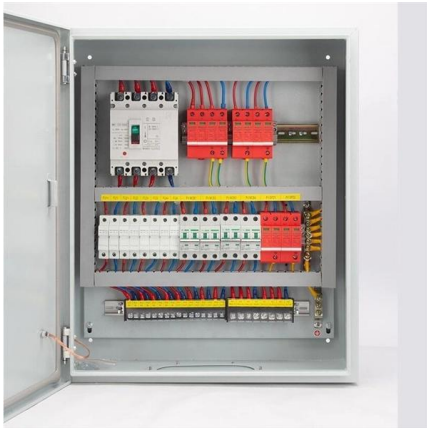

### Distribution Box Guide: Types, Components & Solutions

Understand distribution boxes (DB boxes) in 5 minutes. Learn about types, components, functions, and uses. Find the perfect DB box for your needs.

[Contact Us](#)

### Distribution boards components

Distribution boards (generally only one in residential premises) usually include the meter (s) and in some cases (notably where the supply utilities impose a TT earthing system and/or tariff



[Contact Us](#)



### The Complete Guide to Distribution Box: Installation, Types & More

How do I choose the right size distribution box? Size selection depends on the number of circuits needed, current ratings, and future expansion plans. Calculate the total electrical load and

[Contact Us](#)



## Electrical Distribution Box Design Guide

The document provides details for designing the electrical distribution box and circuits for a residence. It includes specifications for the main circuit breaker such

[Contact Us](#)

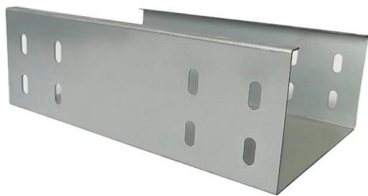

## Comprehensive Understanding of Distribution Box

A distribution box helps manage electricity in homes or workplaces. It makes sure power flows safely and efficiently to devices. Let's look at its main jobs. Power distribution and circuit management The

[Contact Us](#)

## A Complete Guide to Distribution Boards

4-way or 8-way distribution boards are often required for simple circuit dividing and may be suitable for many domestic uses. These small fuse boxes

[Contact Us](#)



## Power Distribution Boxes Explained Simply

Where Power Distribution Boxes Are Used Power distribution boxes are essential in many settings, from homes to hospitals. Here's a look at some

[Contact Us](#)



## Distribution Boxes: Types and Functions

A distribution boxes acts as the load center and main distributor of electrical power within a building. Also called a distribution board, panel board,

[Contact Us](#)



## How th Choose the Right Distribution Box?

The size of a distribution box depends on your circuit capacity and power requirements. For residential spaces, smaller boxes with 4 to 16 circuits

[Contact Us](#)

## Calculate Size of Main ELCB & Branch MCB of Distribution Box

Design Distribution Box of one House and Calculation of Size of Main ELCB and branch Circuit MCB as following Load Detail. Power Supply is 430V (P-P), 230 (P-N), 50Hz.

[Contact Us](#)



## Understanding Distribution Boxes: A Comprehensive Guide

Learn what a distribution box is, its types, and how to choose the right one for your project. Includes clear examples and expert tips.

[Contact Us](#)



## The Complete Guide to Distribution Box: Installation, Types & More

Home distribution boxes typically handle single-phase power supplies and contain 6 to 24 circuits. They include standard circuit breakers for lighting, outlets, and major appliances like water

[Contact Us](#)



## How to Calculate the Size and Number of Circuits for a Distribution

Getting its sizing right isn't just about following rules--it's about safety, efficiency, and avoiding those annoying tripped breakers at 2 AM. Imagine this: You're halfway through cooking Thanksgiving

[Contact Us](#)



## Calculate Size of Main ELCB & Branch MCB of Distribution Box

Design Distribution Box of one House and Calculation of Size of Main ELCB and branch Circuit MCB as following Load Detail. Power Supply is 430V (P-P), 230 (P-N), 50Hz. Consider

[Contact Us](#)



## How to Install a Distribution Box--A Comprehensive

Typically, the size of a residential distribution box ranges from 4 to 20 circuits, while commercial and industrial boxes can range from 20 to 40+ circuits.

[Contact Us](#)



## A Definitive Guide To Distribution Boxes

Power distribution boxes are beneficial because they eliminate the requirement for each output device to be connected directly to the power source. As a result, there's no reason to utilize

[Contact Us](#)

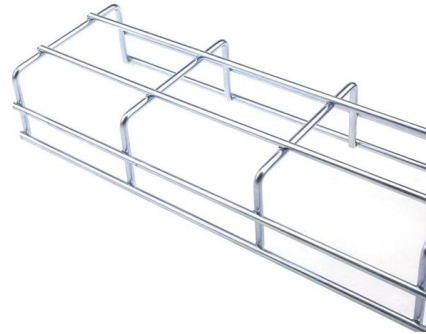

### How to choose the size of the distribution board

Learn how to choose the right distribution board size by assessing load requirements, circuit needs, and future expansions for a safe and efficient setup.

[Contact Us](#)

### Size configuration of multiple circuit breakers in the

Choose the right size and setup for multiple circuit breakers in your distribution box to ensure safety, code compliance, and room for future upgrades.

[Contact Us](#)

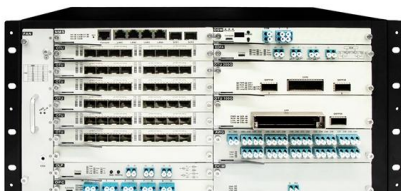

### Business Standard

Hier sollte eine Beschreibung angezeigt werden, diese Seite lässt dies jedoch nicht zu.

[Contact Us](#)



## How to determine the size, installation method and

If all miniature circuit breakers are determined according to the number of digits (each 18 mm), PZ series distribution box has a fixed size. If the circuit exceeds 80

[Contact Us](#)

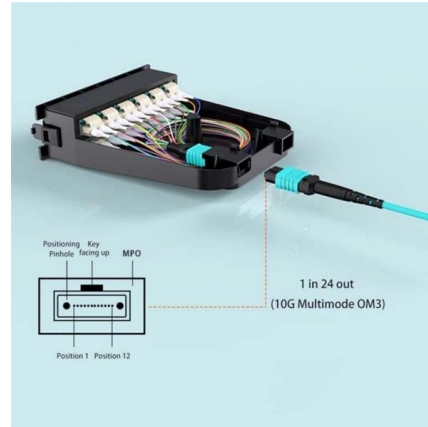

## Distribution Boxes Explained: Types, Functions, and

Beyond simple power distribution, these units provide essential safety measures that protect against electrical hazards like short circuits and power

[Contact Us](#)

## Distribution Box Manufacturer & Supplier , Wilmall

You need to count how many individual circuits your application will require. Each circuit typically needs one slot for a single-pole breaker or two slots for a double-pole breaker (like for a

[Contact Us](#)



## Contact Us

For datasheets, pricing, or custom fiber access solutions, please visit:  
<https://frindel.es>