

# **Geological Raman Spectrometer**





## Geological Raman Spectrometer

---

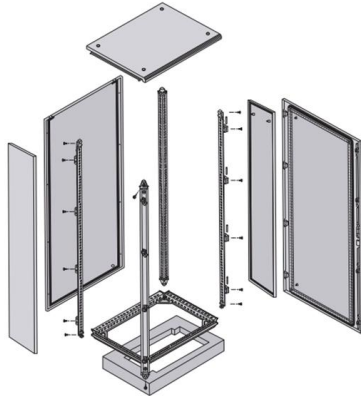

### Raman spectroscopy as a tool to determine the thermal maturity of

Raman spectrometry is a rapid, non-destructive alternative to conventional tools employed to assess the thermal alteration of organic matter (OM).

[Contact Us](#)

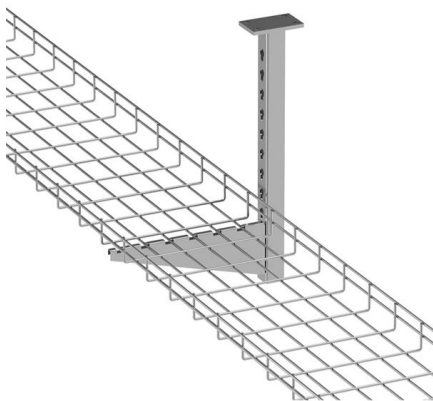

### New insights of origin determination and formation of emeralds from

The inclusion, spectroscopy characteristics and chemical composition of emeralds from these two deposits were systematically analyzed in this study through basic gemological tests,

### Raman Spectroscopy for Mineral Identification: A Practical Guide

With the improvements to and proliferation of Raman instruments, of many sizes and formats, plus the ongoing population of reference Raman databases for minerals, Raman spectroscopy is increasingly

[Contact Us](#)

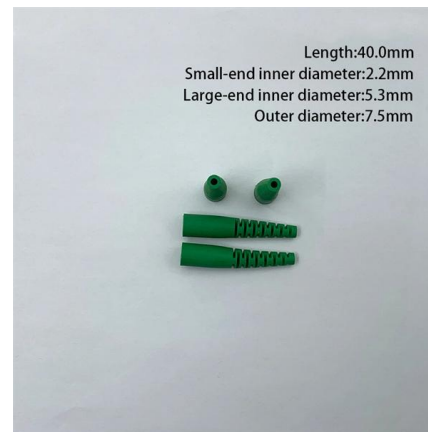

### Fourier-transform infrared spectroscopy

Fourier transform infrared spectroscopy (FTIR) is a technique used to obtain an infrared spectrum of absorption or emission of a solid, liquid, or gaseous material.

[Contact Us](#)



### Raman Spectroscopy for Geological Materials Analysis

Raman spectroscopy is a practical exploration tool to study geo-logical materials. This technique is a rapid and reliable way to confirm, for example, that a geological sample is really a jade gemstone, or

[Contact Us](#)



### An Exceptional View of Geological Materials with Raman Imaging

Raman spectroscopy is clear choice as a tool for analyzing geological samples. It not only provides an excellent way of identifying various mineral components but it also provides detailed structural

[Contact Us](#)



### What Is Raman Spectroscopy and How Does It Work?

Raman spectroscopy identifies materials by analyzing scattered light. Learn how it works, why researchers use it, and where it shows up in pharmaceuticals and forensics.

[Contact Us](#)



### Analyse geological samples with Raman spectroscopy

Renishaw's Raman systems are compatible with most standard geological sample types. Generate images from unprepared, raw samples, polished blocks and thin sections. With LiveTrack(TM)

[Contact Us](#)



### Raman Spectroscopy for Mineral Identification: A Practical Guide

PDF , On Jul 19, 2025, Paul R Bartholomew and others published Raman Spectroscopy for Mineral Identification: A Practical Guide , Find, read and cite all the research you need on ResearchGate

[Contact Us](#)

### Analyse geological samples with Raman spectroscopy

This instrument is particularly useful for geologists as it combines high spatial resolution SEM images and EDX elemental analysis with the detailed chemical information from Raman spectroscopy.

[Contact Us](#)



### Raman Spectroscopy in Geology

Using Raman spectroscopy in geology, mineralogy & gemmology to analyse composition, structural characterisation, stress/strain & crystallographic structure.

[Contact Us](#)



**Research on Raman Spectroscopy in Geology, Rock and Mineral**

Laser Raman spectroscopy has shown good application prospects in the analysis of micro components. In this paper, the laser Raman high-resolution large-area fast imaging method is applied to the full

[Contact Us](#)

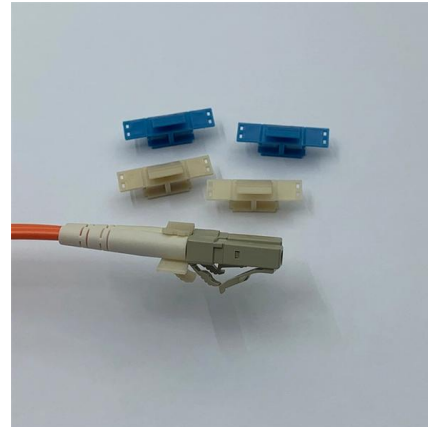

**Study of geological materials with Raman Spectroscopy**

Raman Spectroscopy specificities The Raman effect is highly sensitive to even slight differences in chemical structures. Even if not all vibrations are observable with Raman spectroscopy (depending

[Contact Us](#)

**Geological Materials Analysis Using Raman Spectroscopy**

In order to obtain in-depth information on the history of rock formation, a powerful characterization technique is required. Raman spectroscopy is one such

[Contact Us](#)



**Handbook of Raman Spectra for geology**

We therefore present a selection of Raman spectra of minerals representative of some major mineral groups [use search engine]. The spectra provide the main vibrational fingerprints of each main

[Contact Us](#)



## Study of geological materials with Raman Spectroscopy

Raman spectroscopy is extremely information-rich (chemical identification, characterization of molecular structures, effects of bonding, environment and

[Contact Us](#)



## Geological Materials Analysis Using Raman Spectroscopy

Raman spectroscopy offers high-resolution, non-destructive analysis of geological materials, identifying minerals and fluid inclusions with precision.

[Contact Us](#)

## Application of Raman Spectroscopy in Oil and Gas

Raman spectroscopy has shown considerable potential in the study of organic macerals in source rocks due to its significant benefits of accuracy,

[Contact Us](#)

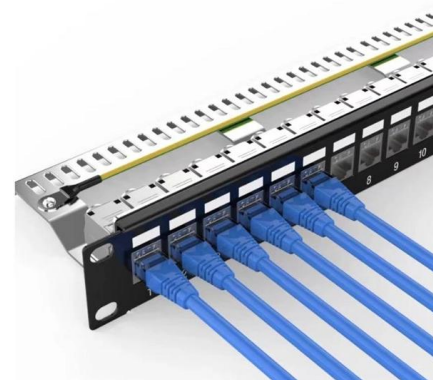

## Raman Spectroscopy in Geology

Raman spectroscopy is a powerful analytical tool in geology and mineralogy, with advantages over alternative techniques.

[Contact Us](#)

## Raman Spectroscopic Analysis of Geological



## and Biogeological

A novel miniaturized Raman spectrometer is scheduled to fly as part of the analytical instrumentation package on an ESA remote robotic lander in the ESA/Roscosmos ExoMars mission to search for

[Contact Us](#)



### **(PDF) Applications of Raman spectroscopy in Geology**

PDF , On Oct 7, 2020, Sergey Mamedov published Applications of Raman spectroscopy in Geology , Find, read and cite all the research you need on

[Contact Us](#)

## Contact Us

---

For datasheets, pricing, or custom fiber access solutions, please visit:  
<https://frindel.es>