

Fiber optic coupler access loss

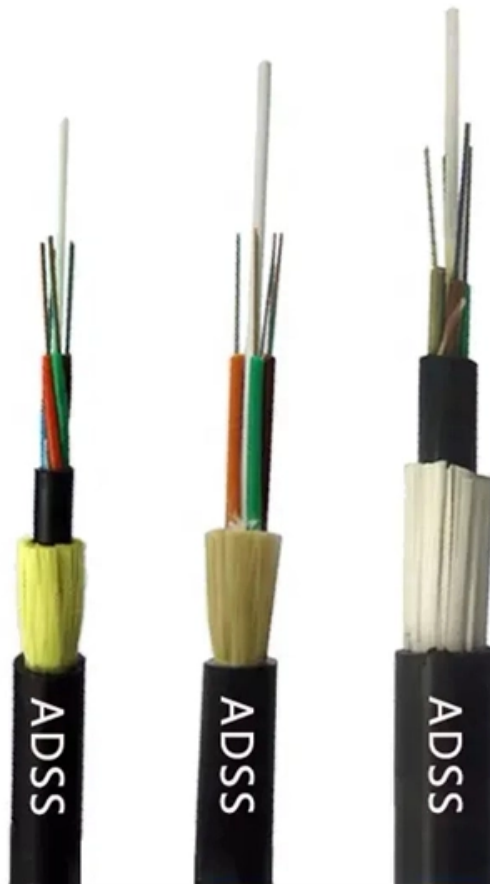



Overview

Insertion loss, also known as attenuation, is the loss of optical power that occurs when light passes through a fiber optic connector. It is caused by factors such as misalignment, air gaps, and imperfections in the connector components. To be able to judge whether a fiber optic cable plant is good, one does a insertion loss test with a light source and power meter and compares that to an estimate of what is a reasonable loss for that cable plant. The estimate, called a "loss budget" is calculated using typical component losses for. Why is wavelength important?

Different wavelengths experience different attenuation levels. Fiber connectors are convenient for connections which need to be released more often. Common connector types are named FC, SC and LC for single-mode applications and ST for multimode, but there are also dozens of other types, with special qualities such as duplex connections, particularly small. This article explores various connector types—such as SC, LC, FC, ST, APC, and UPC—and analyzes how their design and polishing affect IL and RL performance.



Fiber optic coupler access loss



Fiber Joints - connectors, alignment tolerances,

With the fiber optics software RP Fiber Calculator PRO, one can conveniently calculate coupling losses at misaligned fiber joints. For more sophisticated

[Contact Us](#)

Understanding Optical Loss in Fiber Networks

Insertion loss and return loss can impact fiber network performance - this post explains what they are and gives five tips to reduce their impact.

[Contact Us](#)



How To Minimize Insertion Loss in Fiber Coupler Installations

In fiber optics, this loss can occur due to various factors such as splicing, connectors, and couplers. Minimizing insertion loss is crucial for signal optimization, ensuring that the transmitted

[Contact Us](#)

Investigation of coupling loss caused by misalignment in

The main goal of this article is to investigate coupling loss caused by misalignment in optical fiber using the Modicom 6 module.

[Contact Us](#)



Low-loss access coupler for multimode optical fiber distribution networks

High-precision reflectivity measurement technique for low-loss laser mirrors Multimode fiber-optics coupler with low insertion loss

[Contact Us](#)



Return Loss - fiber coupler, Faraday isolator, laser

Return loss is a measure of how much reflected light is attenuated e.g. a fiber splice or connector. A high return loss is often required.

[Contact Us](#)



Factors Influencing the Optical Performance of Fiber Optic

Fusion splicing creates permanent fiber coupling with low insertion loss, high strength and smaller size. However, for temporary connections optical connectors are used to produce quick connections and

[Contact Us](#)

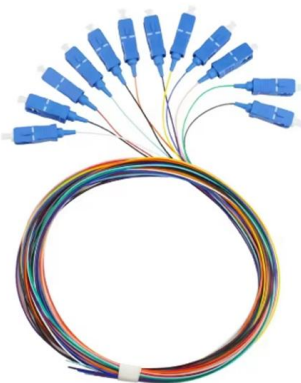

What are the most common fiber optics



problems?

This article discusses the common issues experienced in fiber optic performance. Common problems with fiber Attenuation is the loss of optical

[Contact Us](#)



MPO-MPO Low Smoke Halogen Free Sheath
Multimode 10 Gigabit 12 pole OM4
Insertion loss <0.35dB Return loss >50dB

Reference to Insertion Loss and Return Loss for Fiber

In this comprehensive guide, we will discuss these two parameters, their significance in fiber optic connectors, and the recommended reference

[Contact Us](#)



Fiber Optic Connector Types and Their Impact on

Learn how fiber optic connector types like SC, LC, APC, and UPC influence insertion loss and return loss. Optimize your fiber network with the right

[Contact Us](#)



Principles and Performance of Access Couplers for Multimode Fibers

Access couplers -- both wavelength selective and non-selective -- play an important role in fiber optic communication. Several examples are the monitoring the signal level in a transmission system,

[Contact Us](#)



Optical fiber coupling loss



Ideally, optical signals coupled between fiber optic components are transmitted with no loss of light. However, there is always some type of imperfection present at fiber optic connections that causes

[Contact Us](#)



Fiber Optic Loss Budgets Calculator , Fiber Optic

Master fiber optic loss budgets with FSI's comprehensive guide. Learn calculation methods, best practices, and optimization techniques for high-performance

[Contact Us](#)



Understanding Fiber Loss: What Is It and How to

Accurate measurement and testing in fiber cable installation are crucial to ensure overall network integrity and performance. A significant signal

[Contact Us](#)



Fiber Insertion Loss and Return Loss: A Complete Guide

Then add a fiber jumper and connect it to the optical power meter for testing. You will get a new value, and the difference between the two values is

[Contact Us](#)





Loss in Fiber Optic Adapters: Influencing Factors and

In the realm of modern communication networks, fiber optic adapters are indispensable links that connect fiber optic cables and ensure stable signal

[Contact Us](#)



Fiber Optic Connections and Couplers , Springer Nature Link

Fiber connections such as connectors and splices and the associated intrinsic and extrinsic losses are described. The construction of couplers and branches, including the associated

[Contact Us](#)



Fiber Optics Loss Budget Calculation , Fluke Networks

Know about fiber optics loss budget calculation formula to measure fiber link loss. Download calculator in excel for fiber optical loss budget db calculation.

[Contact Us](#)



Comprehensive Guide to Fiber Optic Couplers and

Couplers and adapters used within the isolating structure allow the connection of different types of optical fibers while ensuring that the loss of the

[Contact Us](#)

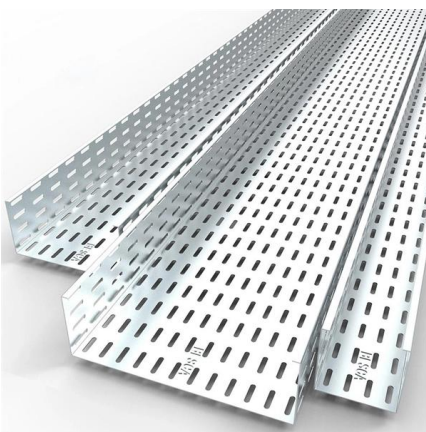



Fiber Insertion Loss, What it is and How to Reduce It

Understand fiber optic insertion loss, how it impacts network performance, and how to reduce it. Contact us for additional resources.

[Contact Us](#)



Insertion Loss - optical power, fiber connector, splice

Examples of Insertion Loss If an optical device is inserted into a setup, some of the optical power may be lost in the device or at optical interfaces. Some examples:

[Contact Us](#)

Considerations for Optical Fiber Termination

Optical fiber channel insertion loss is the decrease in optical power that occurs when an active transmitter is linked to an active receiver via terminated, optical fiber cables and patch cords and

[Contact Us](#)



How Optical Fiber Coupling Works and What Causes Loss

Learn the physics of optical fiber coupling and the precision engineering needed to overcome signal loss caused by alignment errors and intrinsic light

[Contact Us](#)



Simple method of fabricating multimode fiber-optic access couplers

Low-loss access coupler for multimode optical fiber distribution networks B. S. Kawasaki and K. O. Hill Appl. Opt. 16(7) 1794-1795 (1977)
Fabrication of an access coupler with single-strand multimode

[Contact Us](#)

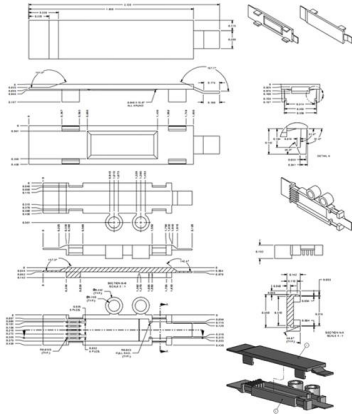

Fiber Optic Loss Calculator

Estimate fiber attenuation, connector loss, splice loss, and budget margin for links. Compare wavelengths, distances, safety reserves, receiver limits, and operating headroom accurately.

[Contact Us](#)

Contact Us

For datasheets, pricing, or custom fiber access solutions, please visit:
<https://frindel.es>