

# Fiber Bragg Grating Sensor Principle Formula

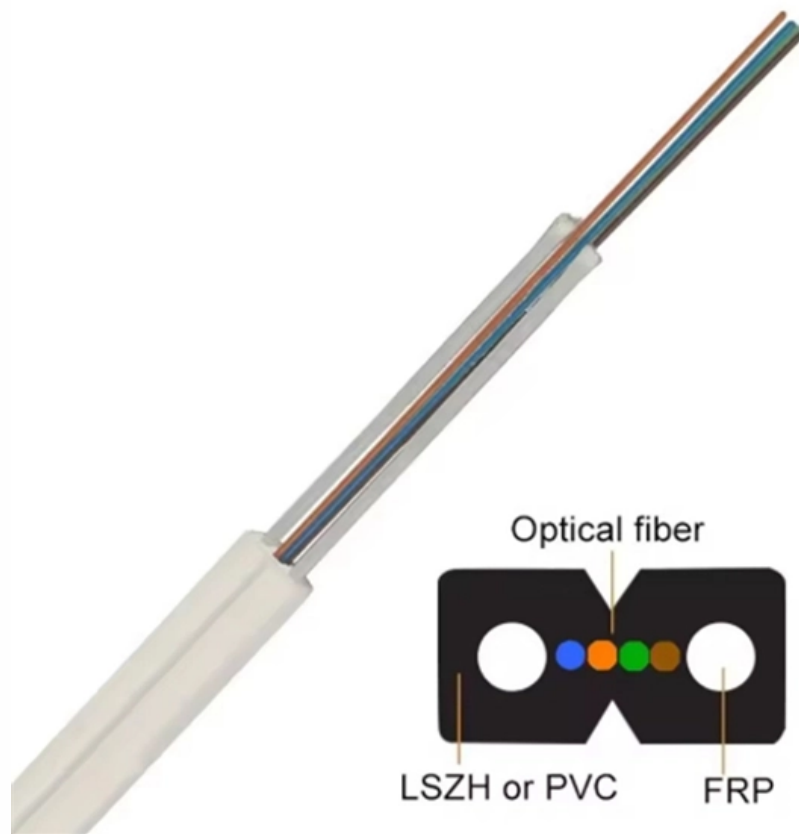



## Fiber Bragg Grating Sensor Principle Formula

---



### Fibre Bragg Grating Sensor

The working principle of fiber Bragg grating (FBG) sensors is based on the reflection of the optical signal that passes through and contracting and expanding optical fiber.

[Contact Us](#)

### Working principle of a fiber-Bragg grating sensor:

The working principle is represented in Fig. 2: an FBG sensor essentially reflects a portion of the incoming probe light spectrum corresponding to the so-called Bragg

[Contact Us](#)



### Fiber Bragg Gratings: Theory, Fabrication, and

Bragg gratings are one of the most useful, reliable, versatile, practical, and attractive passive devices in the fields of optical fiber communications and

[Contact Us](#)



### The Fundamental of Fiber Bragg Grating (FBG) Sensor

The grating inside the fiber optic core must reflect a certain wavelength of incoming light while transmitting all other wavelengths. This wavelength is referred to as the Bragg wavelength or Bragg



### Fiber Bragg Grating Sensors: Design, Applications, and

FBG sensors operate based on the Bragg diffraction principle, where specific wavelengths of light are reflected back when they interact with a

[Contact Us](#)



### Fiber Bragg Grating

3.2 Fiber Bragg grating Fiber Bragg grating (FBG) is a newly developed sensor that has been successfully applied to probe the setting properties and internal temperature variation of cement and

[Contact Us](#)



### A Guide to Fiber Bragg Grating Sensors

Fiber Bragg Grating (FBG) technology is one of the most popular choices for optical fiber sensors for strain or temperature measurements due to their simple manufacture, as we will see later on, and

[Contact Us](#)





**Working principle of a fiber-Bragg grating sensor: wavelength of the**

The working principle is represented in Fig. 2: an FBG sensor essentially reflects a portion of the incoming probe light spectrum corresponding to the so-called Bragg wavelength and allows the

[Contact Us](#)



**Fiber Bragg Grating Based Sensors**

What is Fiber Bragg Grating Based Sensors? In the electrical and electronics industry, presence of high voltage and high electromagnetic interference can fail a electronic sensor. It is near impossible for

[Contact Us](#)

**Fiber Bragg grating sensors: principles and applications**

Their side-writing technique makes a Bragg grating directly in the fiber core using a holographic interferometer illuminated with a coherent ultraviolet (UV) source. Versatility in the fabrication of

[Contact Us](#)



**Fiber Bragg Grating Sensor , Springer Nature Link**

According to the optical structure and sensing principle, fiber gratings are divided into phase shift grating, chirped grating, blazed grating, long period grating, and Bragg grating. Based on

[Contact Us](#)



## Concept and Principle of Fiber Bragg Grating (FBG)

This article introduces the concept of Fiber Bragg Grating (FBG) and explains how FBG works. It explains the principle of FBG using the Bragg

[Contact Us](#)

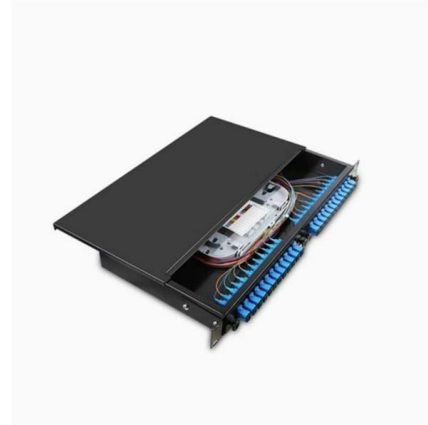

## Comprehensive Review of Fiber Bragg Grating Sensors: Principles

Abstract: Fiber Bragg Grating (FBG) sensors have emerged as versatile tools for various sensing applications due to their unique properties such as small size, immunity to electromagnetic

[Contact Us](#)



## Fabrication and Applications of Fiber Bragg Grating

Abstract: In this paper, the brief introduction of Fiber Bragg Grating, its significant applications, sensing principles, properties, fabrication and the basic designing of FBG have been discussed. FBG's are

[Contact Us](#)



## Fibre Bragg Grating Sensor

Fiber Bragg Grating Sensor The Fiber Bragg Grating (FBG) sensor consists of distributed Bragg reflectors in a short segment of optical fiber that reflects particular wavelength light and transmits all

[Contact Us](#)



## Schematic and principle of a fiber Bragg grating (FBG)

Download scientific diagram , Schematic and principle of a fiber Bragg grating (FBG) sensor. from publication: Optical Fiber Sensors for Monitoring Railway

[Contact Us](#)



## Fiber Bragg Grating Sensors: Principles and Applications

Fiber Bragg grating (FBG) optical sensors have emerged as a leading technology for distributed strain and temperature measurement. Their unique attributes--compactness, immunity to electromagnetic

[Contact Us](#)



## Fiber Bragg Grating Technology , Frequently Asked

Frequently Asked Questions on Fiber Bragg Grating Technology & Systems Optical sensors based on Fiber Bragg Gratings (FBG) are becoming increasingly

[Contact Us](#)



## Fiber Bragg Gratings: The Ultimate Guide

Discover the principles, applications, and benefits of Fiber Bragg Gratings in optical sensors, revolutionizing various industries.

[Contact Us](#)





## Fiber Bragg Grating Sensor: Structure, Working,

A fiber bragg grating can be used as an inline optical filter to block certain wavelengths. The fundamental principle behind its working operation is Fresnel

[Contact Us](#)



## What is a Fiber Bragg Grating? , FBG , Sensors , HBM

A fiber bragg grating (FBG) is just a few millimeters long, highly sensitive and very reliable. Learn more about its properties!

[Contact Us](#)

## Optical sensing using fiber bragg gratings: Fundamentals and

Abstract: In this article, Fiber Bragg Grating (FBG) technology used to implement fiber sensors is explained and some applications in temperature and strain measurements are presented.

[Contact Us](#)

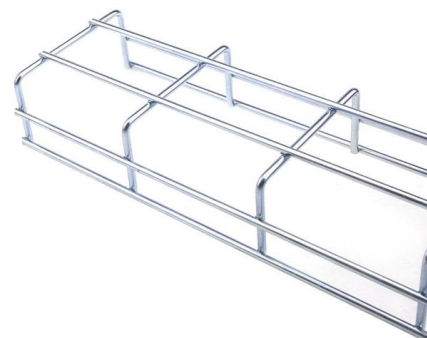

## Fiber Bragg Grating Sensors

A variation of the period of the grating inscribed in a fiber optic - induced by mechanical or thermal perturbation - causes a shift of the reflected peak wavelength, due to the related optical path length

[Contact Us](#)

## What Is Fiber Bragg Grating? The Ultimate

Fiber Bragg Grating enables precise strain and temperature sensing, offering reliable monitoring for structures, machines, and harsh environments.

[Contact Us](#)



### Fiber Bragg grating sensors: principles and applications

Their side-writing technique makes a Bragg grating directly in the fiber core using a holographic interferometer illuminated with a coherent ultraviolet (UV) source. Versatility in the fabrication of

[Contact Us](#)

### Fiber Bragg Grating Sensing Principle

This article explains the principle of Fiber Bragg Grating (FBG) sensors based on the fundamental concept of "reflection and interference of light waves," including the

[Contact Us](#)

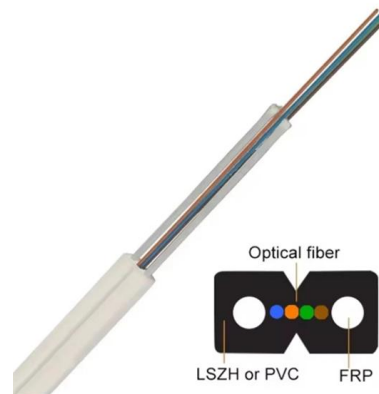

### Recent advancements in fiber Bragg gratings based temperature and

Fiber Bragg Gratings or FBGs have achieved significant attention towards sensing and communication applications due to their outstanding advantages. D

[Contact Us](#)





## Fiber Bragg Grating Based Sensors

An FBG is an optical sensor made by laterally exposing a core of single mode fiber to periodic pattern of intense UV laser light. The exposure forms a permanent

[Contact Us](#)



## Recent Advances in Fiber Bragg Grating Sensing

In the vast realm of optical fiber sensing, where precision and innovation converge, Fiber Bragg Gratings (FBGs) stand as luminaries, casting

[Contact Us](#)

## Working principle of fiber Bragg grating

Gratings with periods  $K$  are commonly fabricated by holographic or phasemask technique [41,79]. The working principle of the Bragg grating sensor is shown in

[Contact Us](#)



## Fiber Bragg Grating

Fiber Bragg Grating (FBG) is defined as a type of optical fiber sensor that operates as a Bragg reflector, allowing for the measurement of strain and temperature by tracking changes in its wavelength peak,

[Contact Us](#)



## Contact Us

---

For datasheets, pricing, or custom fiber access solutions, please visit:  
<https://frindel.es>