

Electrical distribution box circuit entry box





Overview

An electrical distribution box is an enclosed panel that receives incoming power and splits it into multiple downstream circuits. From powering homes and industrial facilities to supporting medium-voltage infrastructure, these enclosures ensure safe, efficient, and reliable power distribution.



Electrical distribution box circuit entry box



Electrical Distribution Box: Complete Panel Types Guide

? Quick Answer: An electrical distribution box is a metal enclosure that houses circuit breakers or fuses, distributing incoming electrical power to

[Contact Us](#)

Distribution Box Guide: Types, Components & Solutions

What is a Distribution Box? A distribution box, or DB box, is a circuit breaker enclosure. It is a vital part and central hub of any electrical system. The

[Contact Us](#)

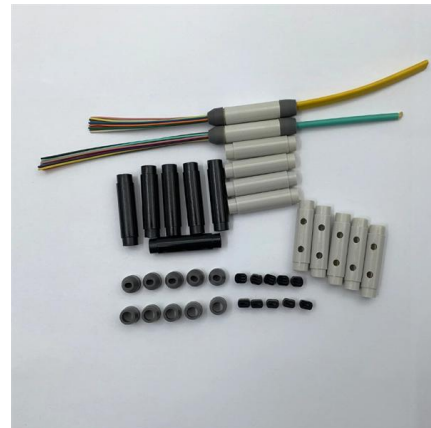

Understanding Distribution Boxes:A Comprehensive Guide

Understanding its significance, this article covers what a distribution box is, how it functions, its structure, the various types available, and how it

[Contact Us](#)



Distribution electrical enclosure, Distribution electrical

The outlet boxes were developed to simplify the power supply of electrical equipment through branch circuits, reducing installation time and providing greater practicality.



Ultimate Guide To Distribution Boxes Db Boxes Types

This ultimate guide explains what a distribution box does, its internal components, common types, real-world applications, and how to select the right DB Box for

[Contact Us](#)



Complete Guide For Distribution Boxes Types

Distribution boxes, also known as electrical distribution boards or panels, are pivotal components in electrical systems, ensuring the safe and organized distribution of

[Contact Us](#)

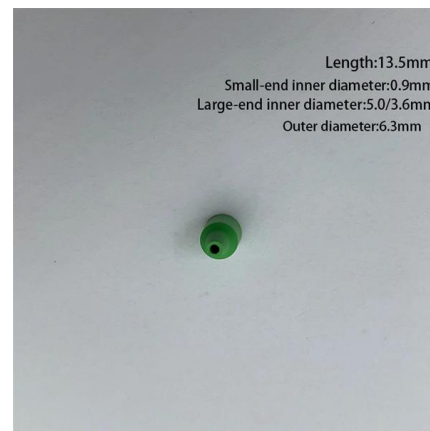

Complete Guide For Distribution Boxes Types

These boxes house various circuit breakers, protective devices, and sometimes meters, which collectively manage and distribute electricity to different circuits

[Contact Us](#)





Electrical Panel Box: Anatomy & How It Works , Penna

An electrical panel box or breaker box controls the entire electricity in your home, so it's important to know its components and how it works.

[Contact Us](#)



Electrical Distribution Boxes: Types, Uses & Selection

Learn how electrical distribution boxes work, their key components, common types, and how to choose the right enclosure for safe and reliable power distribution.

[Contact Us](#)

Distribution Box Guide: Types, Components & Solutions

Understand distribution boxes (DB boxes) in 5 minutes. Learn about types, components, functions, and uses. Find the perfect DB box for your needs.

[Contact Us](#)



What Is a Distribution Box?

Distribution boxes are commonly used in residential and commercial electrical systems. Also known as a distribution board, it's responsible for

[Contact Us](#)

What is the Internal Structure of The Distribution Box



Learn about the internal structure of a distribution box, its components, functions, and key types. Understand its role in electrical systems

[Contact Us](#)



Distribution Boxes Explained: Types, Functions, and

Learn about distribution boxes, their types, functions, and safety features to ensure efficient and secure electrical power distribution in any building.

[Contact Us](#)



Wiley Online Library , Scientific research articles, journals, books

Hier sollte eine Beschreibung angezeigt werden, diese Seite lässt dies jedoch nicht zu.

[Contact Us](#)



Electrical Distribution Boxes for Power Distribution

Electrical distribution boxes for modular power distribution and installation. Flexible distribution solutions for industrial and building electrical infrastructure.

[Contact Us](#)

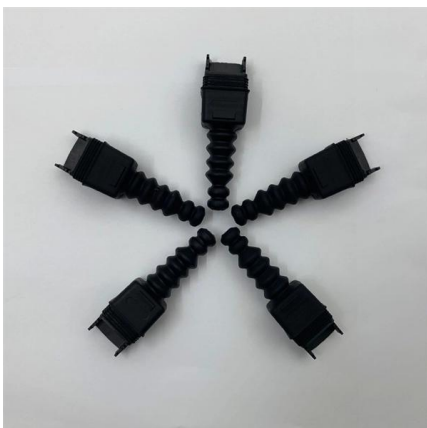



What is a Distribution Box? - A Comprehensive Guide

Key Components of a Electrical Distribution Box
Circuit breakers are essential for protecting electrical systems by cutting off power during overloads or

[Contact Us](#)



A Definitive Guide To Distribution Boxes

The distribution box acts as the center of power distribution, distributing electricity to all connected devices. A distribution box, also known as a distribution board, panel board, breaker

[Contact Us](#)

The Ultimate Guide to Distribution Box Types

In any electrical system, the distribution box is the heart and brain, a critical component that safely manages and distributes power from the main source to

[Contact Us](#)



Understanding Distribution Boxes: A Comprehensive Guide

Learn what a distribution box is, its types, and how to choose the right one for your project. Includes clear examples and expert tips.

[Contact Us](#)



Power Distribution Boxes Explained Simply

Learn what a power distribution box is, how it works, key components, types, and why it's vital for safe and efficient electrical systems.

[Contact Us](#)



What Is an Electrical Distribution Box? A Complete Guide

The electrical distribution box serves a critical role in the safe distribution of power by centralizing circuit control and preventing overloads and short circuits. Its design

[Contact Us](#)

Service entrance Breaker Boxes at Lowes

Breaker boxes support everyday electrical systems by helping you organize circuits and manage power distribution efficiently. They're useful for maintaining

[Contact Us](#)



MPO-MPO Low Smoke Halogen Free Sheath
Multimode 10 Gigabit 12 pole OM4
Insertion loss <0.35dB Return loss >50dB



What is an Electrical Distribution Box? A

An electrical distribution box is often called the control hub of a building's electrical system, and for good reason. It's where power from the main

[Contact Us](#)

How Does a Power Distribution Box Work



Learn how a power distribution box works step by step--from incoming power to circuit protection and smart monitoring--for safe, efficient electricity delivery.

[Contact Us](#)

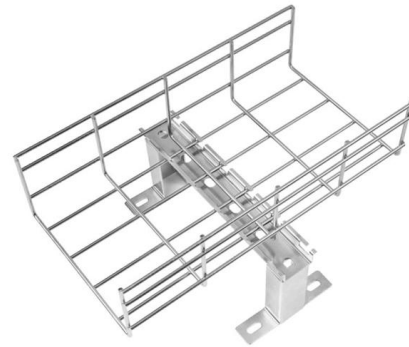

Distribution Box: Types and Functions , Axis-Electricals

A distribution box ensures that electrical supply is distributed in the building, also known as a distribution board, panel board, breaker panel, or electric panel. It is

[Contact Us](#)



Electrical Control Panels & Distribution Boxes: Sizes, Types, and

This guide explores control panels, electrical boxes, breaker panels, bus bars, junction boxes, and custom enclosures to help you understand their sizes, types, and common applications.

[Contact Us](#)



Contact Us

For datasheets, pricing, or custom fiber access solutions, please visit:
<https://frindel.es>