

# **Effect of installing a distribution box in a home**





## Overview

---

Whether in a home or an industrial facility, this box keeps your electrical setup organized, functional, and efficient. If it's done poorly, you risk short circuits, fire hazards, or system. In modern electrical systems, cable distribution boxes (also known as electrical distribution boxes or distribution boxes) play a crucial role as the key hub for managing, distributing, and protecting circuits. It acts as the control center for: ✗ Key functions of a DB Box include: Each component plays a specific role in the home's electrical safety system.



## Effect of installing a distribution box in a home

---



### Understanding Distribution Boards: Your Essential Guide to Electrical

Proper installation and maintenance of distribution boards are essential for ensuring their safe and reliable operation. When installing a distribution board, it's important to follow all relevant

[Contact Us](#)

### How to Choose the Right Distribution Box?

Find out how to choose the right distribution box for your needs! Learn about sizing, safety standards, essential features, and all factors.

[Contact Us](#)



### Size determination, installation method and wiring mode

The distribution box is the central hub of the home circuit and the general control of our daily power consumption. It is an indispensable electrical equipment. If there

[Contact Us](#)



### Where Is the Distribution Box Located and How to Find It

Learn where distribution boxes are typically located in homes and get step-by-step instructions for finding your electrical panel. Includes safety tips and

[Contact Us](#)

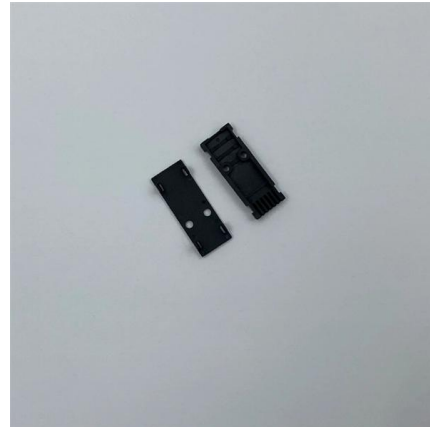

### Distribution boards components

Distribution boards (generally only one in residential premises) usually include the meter (s) and in some cases (notably where the supply utilities impose a TT earthing system and/or tariff

[Contact Us](#)



### Power Distribution Box Essentials: Functions, Types

Power distribution boxes are important in homes, offices, and industries, enabling the smooth and safe flow of power while reducing risks and

[Contact Us](#)



### Understanding Distribution Boxes: Your Guide to Power

Weatherproof Distribution Boxes These serve specific outdoor purposes, with rain, dust, and extreme temperatures sealed shut, protecting any

[Contact Us](#)





## Distribution box

In addition to circuit breakers and RCDs, modern distribution boxes often also contain surge protection, time relays, smart home modules and other components that contribute to efficiency and safety.

[Contact Us](#)



## What Is an Electrical Distribution Box and Why Is It

An electrical distribution box distributes power safely, prevents overloads, and protects circuits, ensuring efficient and reliable electrical systems.

[Contact Us](#)

## How to Choose the Right Distribution Box for Your Home or Workshop

Learn how to choose the right distribution box for your home or workshop. Discover sizing rules, component selection, and strict electrical safety standards.

[Contact Us](#)



## The Complete Guide to Distribution Box: Installation, Types & More

A well-chosen and properly installed distribution box can prevent electrical hazards, reduce downtime, and ensure your electrical system operates smoothly

[Contact Us](#)



## What Is an Electrical Distribution Box? A Complete Guide

An electrical distribution box routes power, prevents overloads, and keeps wiring organised--essential for safe, efficient home and industrial setups!

[Contact Us](#)



### on video How to Wire a Home Distribution Box

How to Wire a Home Distribution Box - Step-by-Step , Distribution DB box wiring diagram Welcome to our channel! In this video, we'll walk you through the

[Contact Us](#)



### Distribution box

The distribution box may only be put into operation once it has passed the test. Extension of existing systems - what you should pay particular attention to Expanding an existing distribution box is a

[Contact Us](#)



### Distribution Boxes Explained: Types, Functions, and

Learn about distribution boxes, their types, functions, and safety features to ensure efficient and secure electrical power distribution in any building.

[Contact Us](#)





## How to Choose a House Distribution Box

Choosing the house distribution box that best fits your home is important for your safety and the efficiency of your electrical system. It facilitates the flow of electricity, guards appliances, and

[Contact Us](#)



## How to Install a Cable Distribution Box Safely and

This article provides a detailed overview of the entire process of installing a distribution box, from pre-installation preparation to post-installation

[Contact Us](#)

## What is a Distribution Box? - A Comprehensive Guide

Whether in homes, offices, or industries, its importance cannot be overstated. Understanding the Basics of a Distribution Box A electrical distribution

[Contact Us](#)

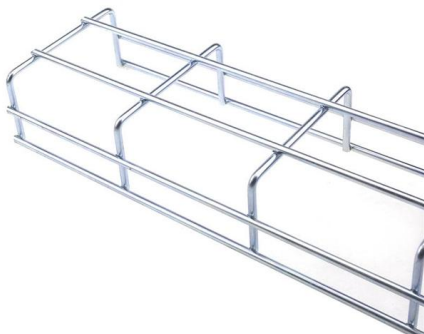

## Distribution Box Installation: A Complete Guide to Safe

The distribution box, often referred to as a breaker box, fuse box, or electrical panel, is a critical component of any electrical system. It acts as the central hub for

[Contact Us](#)



## Importance of Power Distribution Systems in Residential

The design and installation of a power distribution system are critical to its performance and safety. Homeowners should work with licensed

[Contact Us](#)



## Distribution Box: Types and Functions , Axis-Electricals

A distribution box ensures that electrical supply is distributed in the building, also known as a distribution board, panel board, breaker panel, or electric panel.

[Contact Us](#)

## Distribution Box Installation: A Complete Guide to Safe

In this comprehensive guide, we'll cover everything you need to know about distribution box installation, from the basics to the step-by-step installation

[Contact Us](#)



## The installation requirements for the distribution box

Many people don't know the real function of a DB Box and why it's crucial in a home's electrical system. This article explains the role of the DB Box

[Contact Us](#)



## The Importance of Distribution Boxes in Electrical Systems

Distribution boxes are an essential component of any electrical system, providing a safe and reliable way to distribute power to various circuits in

[Contact Us](#)

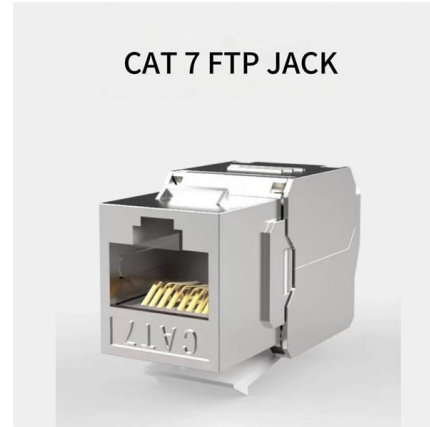

### What Is a Distribution Box?

Distribution boxes are commonly used in residential and commercial electrical systems. Also known as a distribution board, it's responsible for

[Contact Us](#)

## Contact Us

---

For datasheets, pricing, or custom fiber access solutions, please visit:  
<https://frindel.es>