

# **Distribution Box Principles and Construction**





## Overview

---

Distribution boxes are built with durable materials, typically metal or high-grade plastic, designed to endure environmental stresses. They consist of a rigid enclosure housing busbars, circuit breakers, fuses, and wiring terminals. In industrial power distribution systems, cable distribution boxes (also known as power distributor boxes, distribution electrical boxes, or electrical power distribution boxes) are the core hub of power transmission, branching, and protection. Busbars: These are solid strips of copper or aluminum that transfer electricity from the main source to the individual circuits inside the box.



## Distribution Box Principles and Construction

---

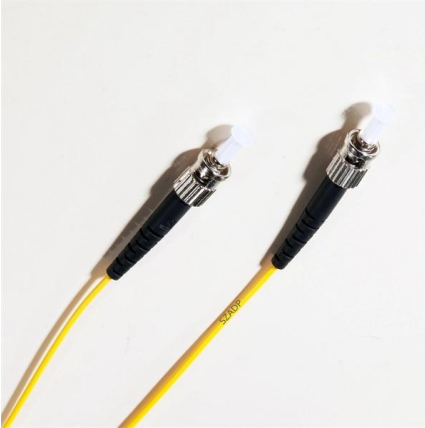

### Distribution Box - Elecon Constructions

Distribution boxes are crucial components in the electrical power distribution network. They play a vital role in ensuring that power supply is efficiently and safely distributed from transformer substations to

[Contact Us](#)

### Comprehensive Understanding of Distribution Box

A distribution box helps manage electricity in homes or workplaces. It makes sure power flows safely and efficiently to devices. Let's look at its main jobs. Power distribution and circuit management The

[Contact Us](#)



### Distribution Boxes Explained: Types, Functions, and

Learn about distribution boxes, their types, functions, and safety features to ensure efficient and secure electrical power distribution in any building.

[Contact Us](#)

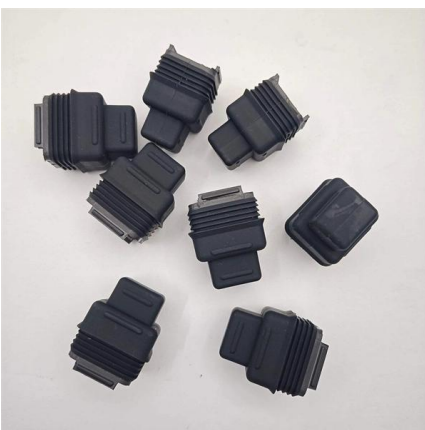

### Cable Distribution Box Layout: 10 Industrial Strategies

Follow the core layout principles to ensure that the cable distribution box network is efficient, easy to maintain, and scalable. The cable distribution box should be installed near the load



### How to Install a Cable Distribution Box Safely and

In modern electrical systems, cable distribution boxes (also known as electrical distribution boxes or distribution boxes) play a crucial role as the key

[Contact Us](#)

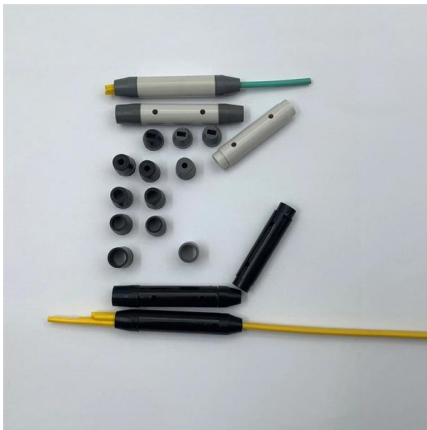

### Size determination, installation method and wiring mode

The distribution box is the central hub of the home circuit and the general control of our daily power consumption. It is an indispensable electrical equipment. If there

[Contact Us](#)

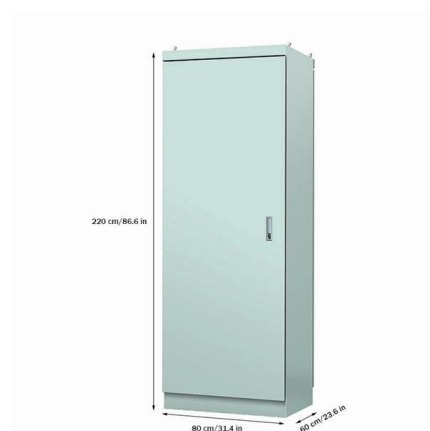

### A Definitive Guide To Distribution Boxes

The distribution box acts as the center of power distribution, distributing electricity to all connected devices. A distribution box, also known as a distribution board, panel board, breaker

[Contact Us](#)





## The Importance of Distribution Boxes in Electrical Systems

Learn more about how distribution boxes play a critical role in the safe and efficient operation of electrical systems.

[Contact Us](#)

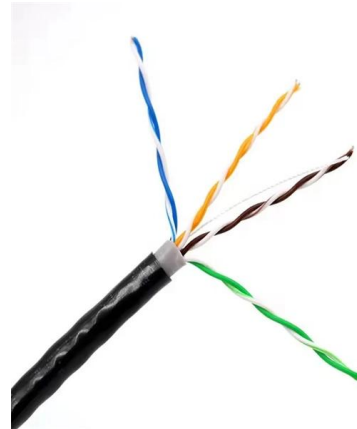

## What Is an Electrical Distribution Box? A Complete Guide

An electrical distribution box routes power, prevents overloads, and keeps wiring organised--essential for safe, efficient home and industrial setups!

[Contact Us](#)

## Ultimate Guide To Distribution Boxes Db Boxes Types

This ultimate guide explains what a distribution box does, its internal components, common types, real-world applications, and how to select the right DB Box for

[Contact Us](#)

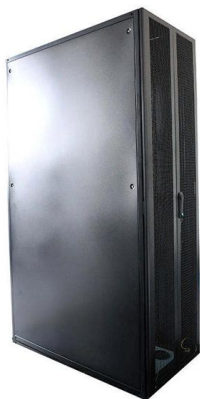

## The Complete Guide to Distribution Box: Installation, Types & More

Blog The Complete Guide to Distribution Box: Installation, Types & More By Admin Aug 2, 2025 No Comments # distribution box Introduction Electrical systems power our homes, offices, and

[Contact Us](#)



## Power Distribution Boxes Explained Simply

Learn what a power distribution box is, how it works, key components, types, and why it's vital for safe and efficient electrical systems.

[Contact Us](#)



## Understanding Distribution Boxes: Your Guide to Power

**Weatherproof Distribution Boxes** These serve specific outdoor purposes, with rain, dust, and extreme temperatures sealed shut, protecting any

[Contact Us](#)

## Distribution Boxes: Types and Functions

Learn what an electrical distribution box (DB/distribution board) is, its main components (MCB/RCCB/RCBO, SPD, busbar) and common types.

[Contact Us](#)

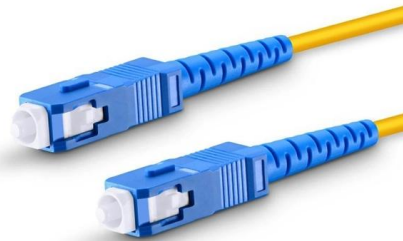

## Distribution Box Guide: Types, Components & Solutions

Understand distribution boxes (DB boxes) in 5 minutes. Learn about types, components, functions, and uses. Find the perfect DB box for your needs.

[Contact Us](#)



## What is a Distribution Box? - A Comprehensive Guide

So, what is a distribution box? It organizes and controls power flow, ensuring safety and efficiency. By managing circuits individually, it prevents

[Contact Us](#)



## Understanding Distribution Boxes: A Comprehensive Guide

A distribution box is a vital piece of equipment that ensures the effective and safe distribution of electrical power in various parts within a building

[Contact Us](#)

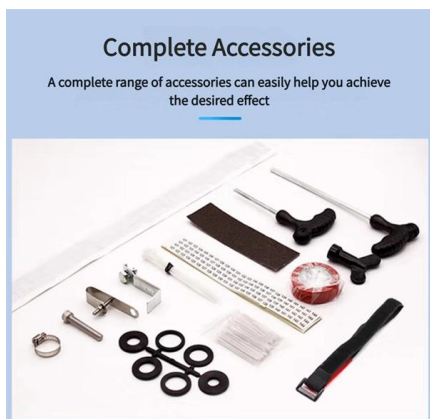

## Distribution Box: Comprehensive Guide on



IP65 / IP67 Sealing Design



Reserved Bottom Mounting Holes

## Understanding Distribution Boxes: The Heart of Electrical Systems

What Is a Distribution Box? A distribution box is an enclosure that holds important components like circuit breakers, fuses, and bus bars. It primarily functions to accept electricity from

[Contact Us](#)

Fast shipment in stock Default white and black, contact customer service for notes

4U standard model



## What is a Distribution Box? - A Comprehensive Guide

A distribution box organizes and controls power flow, ensuring safety and efficiency in electrical systems.

[Contact Us](#)



## Types, Safety & Technology

Explore the essential functions, types, safety features, and technological advances of distribution boxes for efficient electrical power distribution.

[Contact Us](#)



## The Complete Guide to Distribution Box: Installation, Types & More

Understanding the key components of a distribution box helps you make informed decisions about installation and maintenance. Each element plays a specific role in ensuring safe

[Contact Us](#)

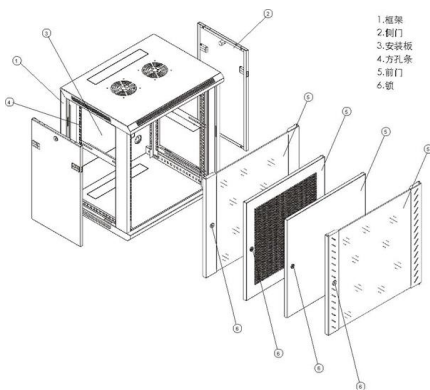

## Working principle of distribution box

## Understanding Distribution Boxes: A Comprehensive Guide

Learn what a distribution box is, its types, and how to choose the right one for your project. Includes clear examples and expert tips.

[Contact Us](#)



## What Is a Distribution Box?

What to Look for When Choosing a Distribution Box If you're going to buy a distribution box, there are several things you should look for. You should

[Contact Us](#)



The distribution box is to assemble the switchgear, measuring instruments, protective appliances and auxiliary equipment in the closed or semi

[Contact Us](#)



### **What is an Electrical Distribution Box? A**

Discover everything you need to know about electrical distribution box! Learn about types, components, and how to choose.

[Contact Us](#)

## **Contact Us**

---

For datasheets, pricing, or custom fiber access solutions, please visit:  
<https://frindel.es>