

# Data Communication Optical Module and Wavelength Division Optical Module

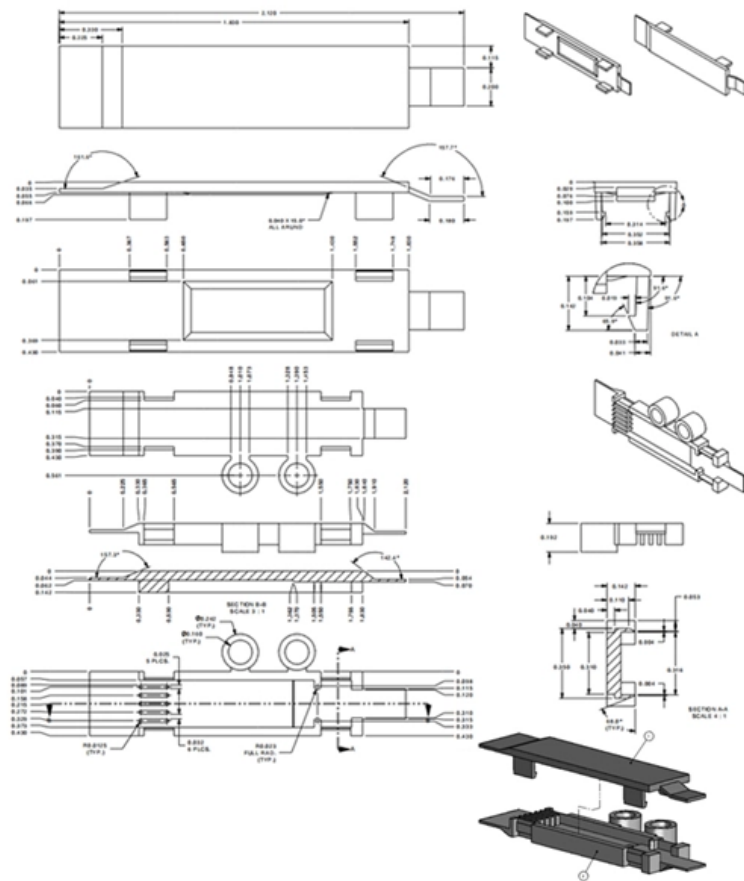



## Data Communication Optical Module and Wavelength Division Optic

---



### Optical Wavelength Division Multiplexing for Data Communication

Publisher Summary Wavelength-division multiplexing (WDM) enables multiple-shift usage of transmission fibers by coupling several wavelengths into the fibers through appropriate optical filters.

[Contact Us](#)

### Wavelength Division Multiplexing

Wavelength division multiplexing (WDM) is a technique of multiplexing multiple optical carrier signals through a single optical fiber channel by varying the

[Contact Us](#)

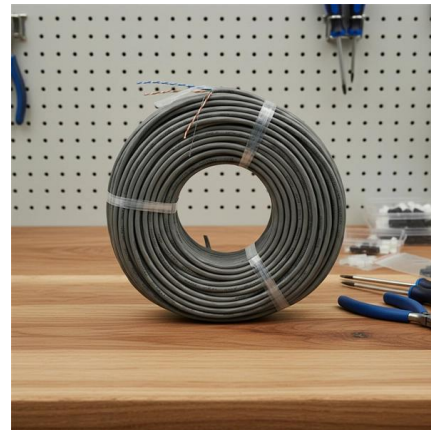

### Optically Multiplexed Systems: Wavelength Division Multiplexing

1. Introduction Since its advent in the mid-1960s, optical technologies and components have been changing the landscape of communication as such. The constant push for higher data rates ensured

[Contact Us](#)



### Wavelength Division Multiplexing (WDM) Tutorial

Wavelength Division Multiplexing (WDM) is a method of using the huge bandwidth of a low-loss area of a single-mode optical fiber to transmit



### **Lightera: Complete Fiber Optic and Connectivity Solutions**

Leader in fiber optic and connectivity solutions, uniting Furukawa Electric's fiber and cable division, Furukawa Electric LatAm and OFS.

[Contact Us](#)



### **Optical Wavelength-Division Multiplexing for Data Communication**

Wavelength-division multiplexing (WDM) enables multiple-shift usage of transmission fibers by transmitting a multitude of wavelengths in suitable transmission fibers. To date, single-mode fibers

[Contact Us](#)



### **The FOA Reference For Fiber Optics**

Read more about coherent fiber optic systems. Sources for Fiber Optic Transmitters The sources used for fiber optic transmitters need to meet several criteria: it has

[Contact Us](#)





## WAVELENGTH-DIVISION MULTIPLEXING OPTICAL NETWORKS

Whereas in the first optical communications networks, light was transmitted through the fiber using a single wavelength, WDM permits light at multiple, different wavelengths, to be transmitted through a

[Contact Us](#)



### Wavelength-division multiplexing

In fiber-optic communications, wavelength-division multiplexing (WDM) is a technology which multiplexes a number of optical carrier signals onto a single

[Contact Us](#)



### Wavelength-division multiplexing

Optical receivers, in contrast to laser sources, tend to be wideband devices. Therefore, the demultiplexer must provide the wavelength selectivity of the

[Contact Us](#)

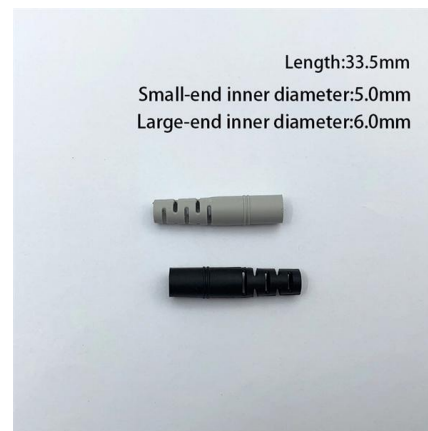

### Wavelength Division Multiplexing (WDM)

Wavelength Division Multiplexing (WDM) Abstract Wavelength division multiplexing or WDM allows the combining of a number of independent information-carrying wavelengths onto the same fiber,

[Contact Us](#)



## WDM: Wavelength Division Multiplexing

Understand the benefits and drawbacks of Wavelength Division Multiplexing (WDM) technology for optical communication.

[Contact Us](#)



## Optical Wavelength-Division Multiplexing for Data Communication

The wavelength spectrum allocation for the L-, C-, S-, E-, and O-bands is discussed. Related technologies, such as time-division multiplexing and erbium-doped fiber amplifiers, are also

[Contact Us](#)



## Introduction to BIDI Optical Module.

What is a BIDI Optical Module? A Bidirectional (BIDI) optical module is a compact, high-performance transceiver used in fiber optic communication

[Contact Us](#)



## Understanding CWDM Optical Modules: From Principles

With high-speed optical modules as its core product, the company specializes in serving the fiber optic communication markets, including

[Contact Us](#)



## Demystifying Optical WDM System: The Key to

Delve into the inner workings of Optical WDM System, understanding how it enables lightning-fast data transmission and revolutionizes connectivity

[Contact Us](#)



## What is WDM and Its Applications in Optical Networking

Wavelength Division Multiplexing (WDM) uses optical transceiver modules to send multiple data streams through a single fiber, boosting bandwidth

[Contact Us](#)

## Research on Optimization and Application of Wavelength Division

This paper discusses in detail the wavelength division multiplexing (WDM) technology, which effectively increases the communication capacity and transmission sp

[Contact Us](#)



## Wavelength Division Multiplexing - WDM, coarse,

The article explains the fundamental principle and its advantages over using a single high-bandwidth channel, particularly in overcoming limitations from electronic

[Contact Us](#)



## Wavelength Division Multiplexing: A Guide to Fiber Optic

Wavelength Division Multiplexing (WDM) systems face several technical challenges despite their advantages in optical communications. These limitations impact

[Contact Us](#)



## Wavelength Division Multiplexing (WDM) , Springer Nature Link

Wavelength division multiplexing or WDM allows the combining of a number of independent information-carrying wavelengths onto the same fiber, because of the wide spectral

[Contact Us](#)

## What is WDM and Its Applications in Optical Networking

Both technologies rely on specialized WDM optical transceiver modules to transmit and receive data across distinct wavelengths, enabling

[Contact Us](#)



## WDM Concepts and Components , Optical Fiber Communications

This chapter focuses on WDM concepts and components used in high-capacity optic-fiber communication networks. The discussion begins with the principle of wavelength division

[Contact Us](#)



## Optical Components and Modules

Integrated PD with tap or WDM function provides high performance and reliability in a compact package. The monitoring product family includes advanced modules

[Contact Us](#)



## Wavelength Division Multiplexing: A Comprehensive Guide

Discover the comprehensive guide to Wavelength Division Multiplexing, its role in optical properties, and its significance in modern telecommunications.

[Contact Us](#)

## Wavelength-Division Multiplexing

Wavelength Division Multiplexing (WDM) is defined as an approach that multiplexes multiple wavelength channels from different end-users into a single fiber, facilitating the transmission of various services

[Contact Us](#)



## Global Leader in Materials, Networking, and Lasers

Communications Transform global communications networks with our comprehensive portfolio of coherent transceivers and modules, lasers, amplifiers,

[Contact Us](#)



## Contact Us

---

For datasheets, pricing, or custom fiber access solutions, please visit:  
<https://frindel.es>