

Complete Guide to Circuit Diagrams for Level 3 Distribution Boxes

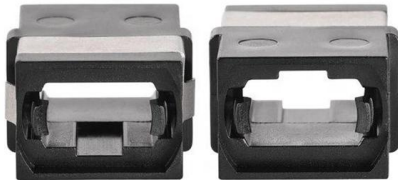



Complete Guide to Circuit Diagrams for Level 3 Distribution Boxes



A Definitive Guide To Distribution Boxes

Power distribution boxes are beneficial because they eliminate the requirement for each output device to be connected directly to the power source. As a result, there's no reason to utilize

[Contact Us](#)

Wiring of A Three Phase Distribution Board

Wiring a Three Phase Distribution Board is of a necessity when the Power Distribution requirement cannot be handled by a Single Phase Power Supply.

[Contact Us](#)

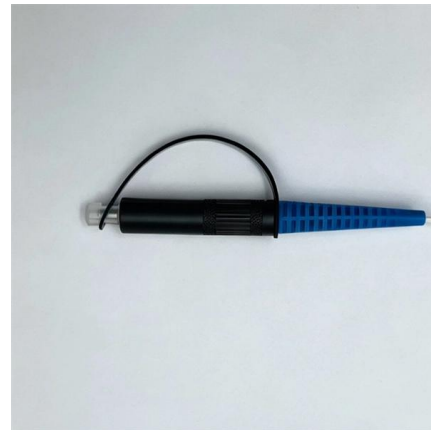

The Meaning and Function of Primary, Secondary, and Tertiary

Differences Between Primary, Secondary, and Tertiary Distribution Boxes Primary Distribution Box: Designed specifically for construction sites, conforming to relevant electrical codes.

[Contact Us](#)



Distribution Boxes Explained: Types, Functions, and

Learn about distribution boxes, their types, functions, and safety features to ensure efficient and secure electrical power distribution in any building.



Electrical Distribution Fundamentals Design Guide Data Bulletin

This guide discusses the main considerations that must be taken into account to obtain an optimal system design. Because the characteristics of each load, process, or other issue, are

[Contact Us](#)



What Is an Electrical Distribution Box? A Complete Guide

An electrical distribution box is a centralized unit responsible for distributing electrical power across multiple circuits within various environments, including residential,

[Contact Us](#)



Three (3) Phase Distribution Board Wiring Diagram and

The three-phase distribution board is carefully designed to receive electrical power from a three-phase supply and distribute it to multiple circuits

[Contact Us](#)





Understanding Distribution Boxes: A Comprehensive Guide

A distribution boxes is an essential device that manages the safe and efficient flow of electrical power throughout different areas of a building or facility.

[Contact Us](#)



A Step-by-Step Guide to Wiring an Electrical Panel Box

Find out how to properly wire an electrical panel box with a comprehensive diagram and step-by-step instructions.

[Contact Us](#)



Understanding Distribution Boxes: A Comprehensive Guide

A distribution box is a vital piece of equipment that ensures the effective and safe distribution of electrical power in various parts within a building

[Contact Us](#)



FundOfDistr.PDF

Although the modern single-phase system uses three-phase. It actually consists of three and one neutral wire. Use of the three wires in different electrical voltages. For example, one circuit can be the

[Contact Us](#)





Advanced Distribution Board Diagram with SPD: Key

Discover an advanced distribution board diagram with SPD in our latest blog post. Enhance your understanding of electrical systems and safety measures.

[Contact Us](#)



3 Phase Distribution Board MCCB Wiring Diagram

Complete wiring diagram for 3 phase distribution board with MCCB, showing connections for incoming supply, breakers, and load distribution for safe

[Contact Us](#)

3 Wire Wiring Diagram Explained and Setup Guide

Learn how to read and create a 3 wire wiring diagram for various electrical systems. Step-by-step guide with tips for proper wiring connections and safety.

[Contact Us](#)



How to Wire 3-Phase, 400V Distribution Board? IEC

A distribution board is also known as main breaker box, electric panel or panel board used in commercial (as industrial) and domestic (as residential) applications to

[Contact Us](#)



3 Phase Distribution Board Layout and Wiring Diagram /

I try to explain three phase distribution board layout and wiring

[Contact Us](#)



Pre-Terminated Patch Panel

- Standard 19" width
- Max 144 fibers in 1U
- Ultra-High Density Ready

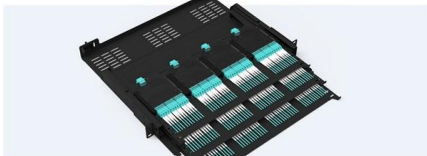

Dual-row, easy install & maintain



Lightweight ABS MPO cassette



Premium sheet metal with multi-coating

Industrial 3 Phase Electrical Distribution Box Guide

Explore the essentials of industrial 3 Phase Electrical Distribution Box for efficient power management in commercial settings. Get expert insights now.

[Contact Us](#)

Electric Power Distribution System Basics , Electrical A2Z

The article provides an overview of electric power distribution systems, focusing on one-line diagrams, busways, and grounding. It explains how

[Contact Us](#)

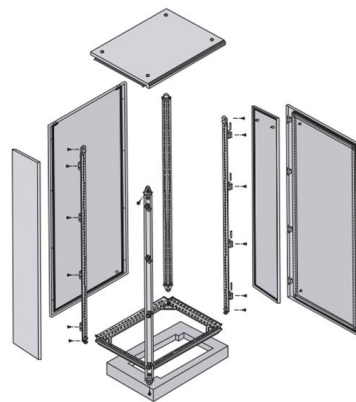

Understanding Distribution Boxes: Your Guide to Power

In the safe and effective supervision of electrical systems, distribution boxes may be the last quite unnoticed yet they are extremely fundamental part.

[Contact Us](#)

The installation requirements for the



distribution box

Learn how to install a distribution box safely and correctly. Covers wiring, placement, standards, and expert tips for a compliant setup.

[Contact Us](#)



Distribution Boxes Types - The Complete Guide

The power distribution boxes deliver electricity from the main electrical main to other circuits. Several distribution boxes are designed for specific use in

[Contact Us](#)



The difference between the first, second, and third levels of

Third level distribution box: refers to the final junction box of each electrical appliance, which can be movable and fixed. Remember that the leakage protection switch is the last one, and

[Contact Us](#)



Understanding Circuit Breaker Wiring Configurations in

Correct wiring methods for circuit breakers within distribution boxes are fundamental to ensuring electrical safety and compliance with established codes.

[Contact Us](#)





Power Distribution Boxes Explained Simply

Learn what a power distribution box is, how it works, key components, types, and why it's vital for safe and efficient electrical systems.

[Contact Us](#)

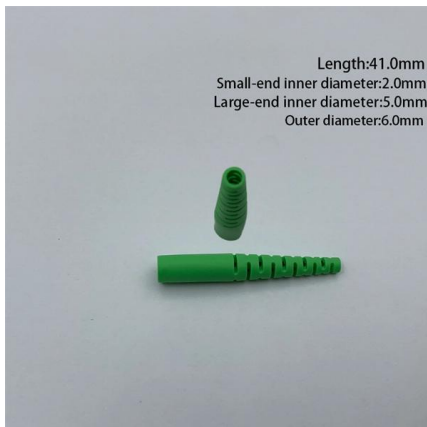

Electrical Distribution Box Diagrams , PDF , Power

This document provides a list of components in an electrical distribution box with their names and associated wiring diagrams. It includes tables of diodes, fuses,

[Contact Us](#)

Distribution Box and Selection Guide

Different settings have distinct electrical requirements: Residential: Homes typically require single-phase power and a Distribution Box with fewer

[Contact Us](#)

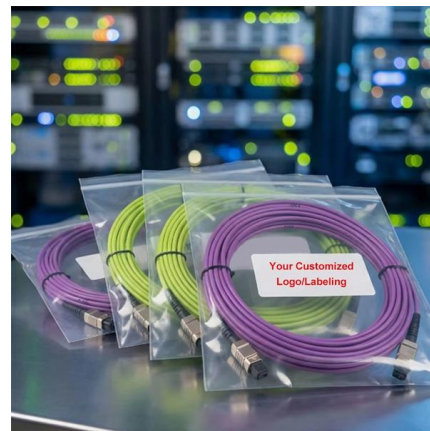

Contact Us

For datasheets, pricing, or custom fiber access solutions, please visit:
<https://frindel.es>