

# **CE certification for explosion-proof distribution boxes**

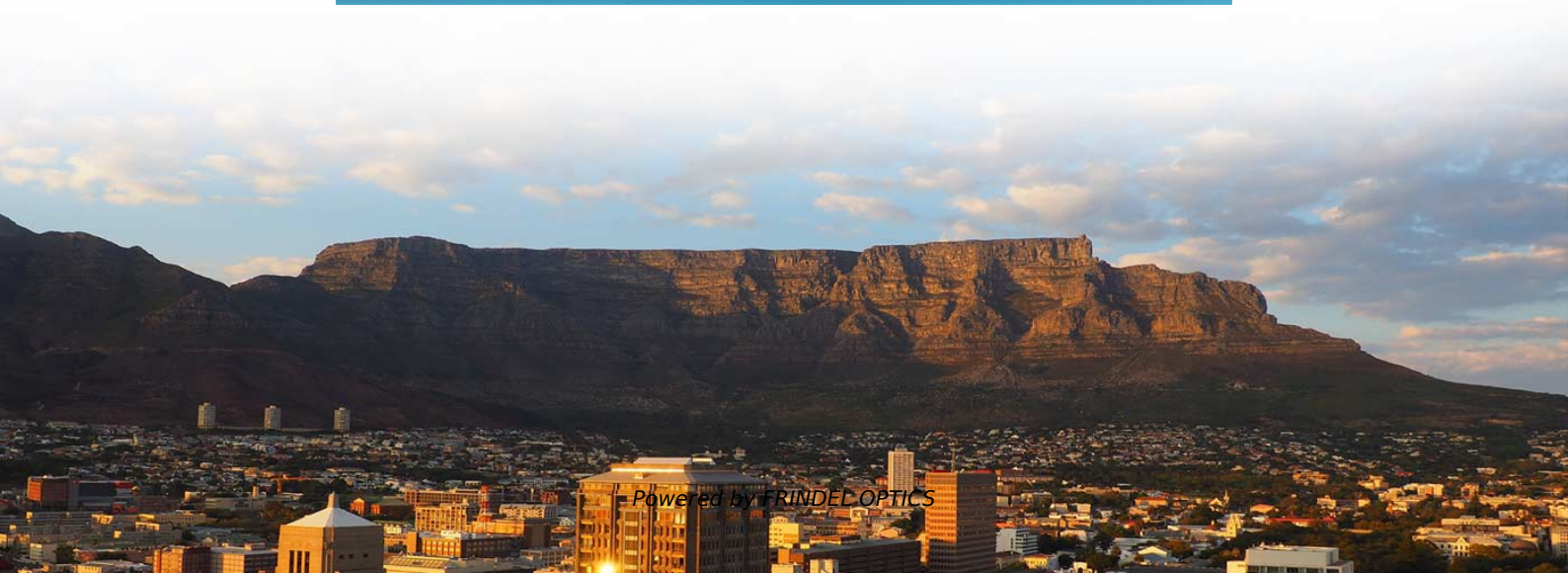



## Overview

---

The CE certification process begins with identifying applicable EU directives—primarily the ATEX Directive for explosion-proof items. The next step involves compiling a technical file, conducting a risk analysis, and undergoing product testing. In this guide, we'll walk together through what really matters: the actual tests your distribution box must pass, and the documents that prove it's worthy of that CE mark. Ex proof equipment is designed to function safely in hazardous areas where gases or dust could ignite.



## CE certification for explosion-proof distribution boxes

---



### EXPLOSION PROOF DISTRIBUTION BOXES, HAZARDOUS AREA BOXES

Marechal B2X The Marechal B2X hazardous area and explosion proof range of distribution boxes up to 750V are equipped with Marechal CRIC increased safety 'e' terminal blocks and cable glands. The

[Contact Us](#)

### Custom CZ1290 Explosion-proof distribution boxes

CZ Electric Co., Ltd is a Custom CZ1290 Explosion-proof distribution boxes suppliers and company, Modular design Easy operations with windows Operating handles

[Contact Us](#)



### Ex Local Control Stations & Distribution Boxes

Atex control stations, explosion protected control units and distribution boxes made stainless steel maritime grade AISI 316L or AISI 304L. Atex Delvalle provides a

[Contact Us](#)

### Custom CE90 Explosion-proof distribution panel

CE90 Explosion-proof distribution panel (Moveable) Prodcuts Features: The distribution box could be portable or movable, which is easy to use. Equipped



### Custom CE31-2 Explosion-proof distribution boxes

About CZ CZ Electric Co., Ltd was established in 1990, is a CE31-2 Explosion-proof distribution boxes (circuit breakers) suppliers, and is headquartered in Jiaxing

[Contact Us](#)



### Explosion-Proof Electrical Distribution Boxes: Applications in

Certification standards for explosion-proof electrical distribution boxes are critical for ensuring safety in hazardous environments. Key classifications include NFPA and NEC guidelines, along with

[Contact Us](#)



### Explosion Proof Distribution Boxes

Explosion proof distribution box components for use in hazardous areas - Zone 1 and 2; Zone 21 and 22.

[Contact Us](#)





## **Terminal boxes , Junction boxes , Ex , Ex e , Ex d , ATEX , Explosion**

Our products are certified for installation technologies all over the world. Standard models available with short delivery times or custom-made terminal boxes - so that you are protected in hazardous areas

[Contact Us](#)



## **Explosion Proof Enclosures , Complete Hazardous Area**

Learn everything about explosion proof enclosures for hazardous areas--design, certification, and industrial applications with ATEX, IECEx, and Class I Div

[Contact Us](#)

## **CE Certification for Distribution Boxes: Key Testing Items and**

In this guide, we'll walk together through what really matters: the actual tests your distribution box must pass, and the documents that prove it's worthy of that CE mark.

[Contact Us](#)



## **Is CE Certificate Mandatory for Ex-Proof Products**

The CE certification process begins with identifying applicable EU directives--primarily the ATEX Directive for explosion-proof items. The next step involves compiling a technical file,

[Contact Us](#)



## BXM (D)51 Series Explosion proof Distribution Boxes

BXM (D)51 Explosion proof Distribution Boxes  
Explosion protection to -CENELEC -IEC -NEC Can  
be used in Zone 1 and Zone 2 Zone 21 and Zone  
22 Class I, Zone

[Contact Us](#)

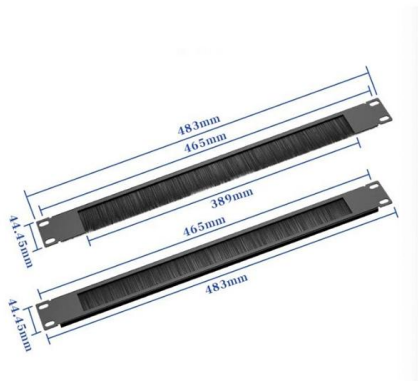

## CE Certification for Distribution Boxes: Key Testing Items and

That's exactly why CE certification isn't just paperwork - it's a promise that your product won't become the weak link in someone's home or business safety. In this guide, we'll walk together through what

[Contact Us](#)



## Distribution box solutions for explosion-proof environments in

## Ex Isolation Switch/Safety Switch/Circuit Breaker Manufacturers

CZ Electric Co., Ltd is an Explosion-proof isolation switch manufacturers and Explosion-proof safety switch, Explosion-proof circuit breaker (MCB) box factory.

[Contact Us](#)



## CE91 Explosion-proof illumination distribution boxes(with

CE91 Explosion-proof illumination distribution boxes (with electrical leakage protection) Home > Atex Certified Products > Atex Junction Boxes >

[Contact Us](#)



Explosion-proof distribution boxes represent where regulatory wisdom meets engineering excellence. What appears as simple protective enclosures are actually sophisticated safety systems honed

[Contact Us](#)



### Terminal and Junction Boxes (Ex d) , Explosion Protection

These sturdy solutions are certified according to global standards such as ATEX, IECEx, UL, and others, making them suitable for safe signal and power distribution in Zone 1, Zone 2, Zone 21, Zone 22, or

[Contact Us](#)

### Top 3 Facts About Explosion Proof Distribution Box & Electrical

In this article, we will explore three key aspects: certification standards, material selection, and application-specific design considerations. Explosion proof enclosures keep people and



[Contact Us](#)



### Explosion-Proof Distribution Box , Product Center

Explosion-proof distribution boxes are designed to safely control and distribute electrical power in hazardous environments, preventing ignition risks.

[Contact Us](#)



## Explosion Proof Distribution Box & Electrical Enclosures

Durable Hexlon Explosion Proof Distribution Boxes and Electrical Enclosures, IECEx and ATEX certified for Zone 1 and Zone 2.

[Contact Us](#)



## Explosion Proof Basics on Product Certification

After a successful Conformity Assessment, the product will display the CE mark, provided that it complies with any other applicable directives (Low

[Contact Us](#)



## Certified Explosion-Proof Distribution Box

The explosion-proof distribution box safely delivers power in hazardous zones (oil, gas, chemical plants) with rugged, spark-resistant casing--ATEX/IECEX, IP66 certified for reliable operation in explosive

[Contact Us](#)



## Ex Isolation Switch/Safety Switch/Circuit Breaker Manufacturers

The main products have obtained ATEX EU explosion-proof certification and IECEx international explosion-proof certification. CZ has agents or offices in 28 countries and regions, and welcomes

[Contact Us](#)





## **ATEX markings explained , CE and Ex marking requirements , Artidor**

The CE marking confirms compliance with all applicable EU directives, while the Ex marking specifically shows that the product is suitable for use in potentially explosive atmospheres under the ATEX

[Contact Us](#)



## **Terminal boxes , Junction boxes , Ex , Ex e , Ex d , ATEX , Explosion**

Safely conduct, connect and distribute energy in hazardous areas with R. STAHL's terminal boxes. We offer bespoke, custom-made terminal boxes and terminal box combinations, as well as standard

[Contact Us](#)

## **ATEX/IECEX Certified Explosion Proof Junction Box**

Prolux provides you with the No.1 quality ATEX & IECEX certified explosion proof junction box at the best-discounted rates. We are the top ex. proof junction boxes

[Contact Us](#)



## **Explosion-Proof Distribution Boxes: Special Installation Requirements**

These environments require electrical distribution boxes that don't just contain sparks but withstand massive internal explosions. Certification standards like ATEX, IECEX, and NEC Class I/II Division

[Contact Us](#)



## Contact Us

---

For datasheets, pricing, or custom fiber access solutions, please visit:  
<https://frindel.es>