

Basic of Explosion-proof Distribution Box





Overview

Explosion proof distribution boxes and electrical enclosures are critical components for ensuring safety in hazardous environments. They are designed to contain internal explosions and prevent ignition of surrounding flammable gases or dust.



Basic of Explosion-proof Distribution Box

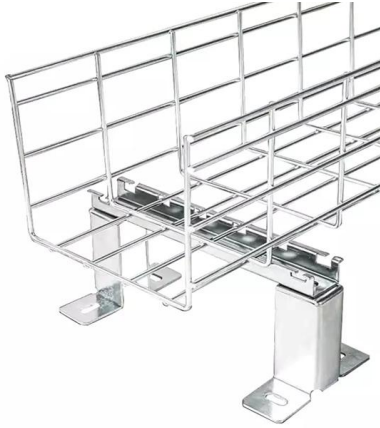

Explosion-proof distribution box: the "invisible guard" protecting

An explosion-proof distribution box is a special electrical equipment designed for flammable and explosive environments. Its shell is made of high-strength materials (such as

[Contact Us](#)

Explosion proof distribution box standards and installation issues

Explosion-proof distribution boxes are mainly used in coal mines, fire stations, petroleum, petrochemical installations and textile and other flammable and explosive places.

[Contact Us](#)



Explosion-Proof Distribution Boxes for Hazardous Areas

Learn how explosion-proof distribution boxes improve electrical safety, prevent ignition risks, and ensure reliable power distribution in hazardous environments.

[Contact Us](#)

Wholesale Explosion-proof Electrical Manufacturers,

As an Explosion-proof electrical manufacturers and factory, The products cover a complete series from explosion-proof components to the integration of electronic



5 Key Factors to Consider When Selecting Explosion Proof Distribution Boxes

Selecting explosion-proof distribution boxes protects the safety of your staff in any potentially hazardous workplace. HEXLON stands out as a trusted provider of explosion-proof

[Contact Us](#)



Explosion Proof Power Distribution Boxes

Flameproof and explosion proof, these power overhaul distribution boxes are suitable for use in hazardous areas. Specs: Ex mark: Ex de IIC T4 Gb DIP A21 TA,T4

[Contact Us](#)



Explosion Proof Illumination Distribution Boxes (With

Flameproof and explosion proof, these power overhaul distribution boxes are suitable for use in hazardous areas. Specs: Ex mark: Ex de IIC T4 Gb DIP A21 TA,T4

[Contact Us](#)





Explosion Proof Enclosure Comprehensive Guide

Explosion-Proof Distribution box: These smaller components are structurally similar to distribution cabinets. You can use these for the distribution

[Contact Us](#)



Distribution Boxes

Distribution Boxes BXM (D)8061 Explosion proof Distribution Boxes Lighting or Power (Ex db ec IIC)

[Contact Us](#)

Explosion-proof distribution box: the "invisible guard" protecting

Ordinary distribution boxes may become a safety hazard in high temperature, corrosive or flammable environments. The explosion-proof distribution box uses explosion-proof, anti

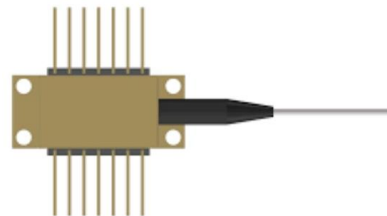

[Contact Us](#)



Explosion-Proof Distribution Box , Product Center

Explosion-proof distribution boxes are designed to safely control and distribute electrical power in hazardous environments, preventing ignition risks.

[Contact Us](#)



Basic Circuit Law Of Explosion-Proof Distribution Box

Explosion Proof Cable Gland supplier would like to share with you. According to the two-part ohm law, when the voltage U is applied at both ends of

[Contact Us](#)



Explosion proof Distribution Boxes HLDP03-M Malaysia

Explosion proof Distribution Boxes HLDP03-M Malaysia Zone 1 and Zone 2 Zone 21 and Zone 22 Meet the necessities in the following industries, such as petroleum,

[Contact Us](#)

Explosion-Proof Terminal Box Design for Hazardous

The explosion-proof terminal box is far more than a protective shell for electrical connections. Its material selection, structural design, cable entry

[Contact Us](#)



Explosion Proof Distribution Box & Electrical Enclosures

Durable Hexlon Explosion Proof Distribution Boxes and Electrical Enclosures, IECEx and ATEX certified for Zone 1 and Zone 2.

[Contact Us](#)



Full Guide on Explosion-Proof Distribution Panel

Explosion-proof distribution panels are vital components in hazardous industrial environments, ensuring safety by preventing electrical equipment from igniting

[Contact Us](#)



Distribution Box Guide

Explosion-Proof Distribution Box: If you're working in hazardous environments--think areas with explosive gases or dust--you'll need an explosion-proof distribution box. These are

[Contact Us](#)

HRMD91 Explosion proof Distribution Box (Ex d IIB+H2)

HRMD91 Explosion proof Distribution Box
Explosion protection to - IEC - CENELEC - NEC
Can be used in Zone 1 and Zone 2 Zone 21 and Zone 22 Class I, Zone 1

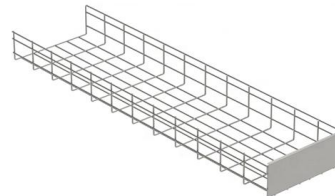

[Contact Us](#)



Distribution box solutions for explosion-proof environments in

Explosion-proof distribution boxes represent where regulatory wisdom meets engineering excellence. What appears as simple protective enclosures are actually sophisticated safety systems honed

[Contact Us](#)

Explosion-Proof Corrosion-Resistant



Distribution Box BXM (D)8030

BXM(D) 8030 Explosion-Proof Corrosion-Resistant Distribution Box, designed for hazard zones, ensures safe power control and prevents ignition risks.

[Contact Us](#)



Explosion-Proof Electrical Box: Principles, Selection, and Industrial

Comprehensive guide on explosion-proof electrical boxes, including definitions, classifications, selection guidelines, testing certifications.

[Contact Us](#)

Explosion-Proof Electrical Distribution Boxes: Applications in

What Is an Explosion-Proof Distribution Box? An explosion-proof distribution box is a specialized enclosure designed to contain internal explosions and prevent the escape of flames, sparks, or hot

[Contact Us](#)

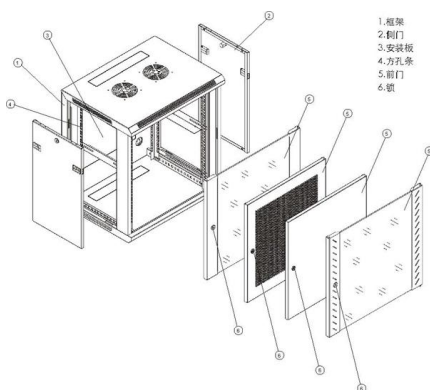

What is Explosion Proof Distribution Box?

Conclusion: Ensuring Safety with Explosion Proof Distribution Boxes Explosion Proof Distribution Boxes are indispensable in ensuring safety and operational continuity

[Contact Us](#)

How to Wire an Explosion-Proof Distribution Box and



Explosion-proof electrical equipment, such as explosion-proof distribution boxes, is specifically designed for hazardous environments where flammable gases,

[Contact Us](#)



Model and Specification of Explosion-Proof Distribution Box

Explosion-proof lighting distribution boxes and cabinets come in a variety of models. They vary in terms of materials, including metal and flame-retardant plastic; installation methods, such as

[Contact Us](#)



Top 3 Facts About Explosion Proof Distribution Box & Electrical

Learn the top 3 facts about explosion proof distribution boxes & electrical enclosures--certifications (ATEX, IECEx, NEMA), durable materials, and customization for

[Contact Us](#)



Energy Distribution

BARTEC offers one of the most extensive ranges of explosion-proof and substance-resistant components, devices, and systems for controlling, switching, and

[Contact Us](#)





Explosion-Proof Box: Essential Safety in Hazardous Areas

Learn what an explosion-proof box is, its types, certifications, applications, and how to choose the right one for safety in explosive environments.

[Contact Us](#)



Top 3 Facts About Explosion Proof Distribution Box & Electrical

Explosion proof distribution boxes and electrical enclosures are critical components for ensuring safety in hazardous environments. They are designed to contain internal explosions and

[Contact Us](#)



Distribution box solutions for explosion-proof environments in

That's where explosion-proof distribution boxes become the unsung heroes of industrial safety. These aren't just metal boxes; they're meticulously engineered fortresses designed to contain potential

[Contact Us](#)

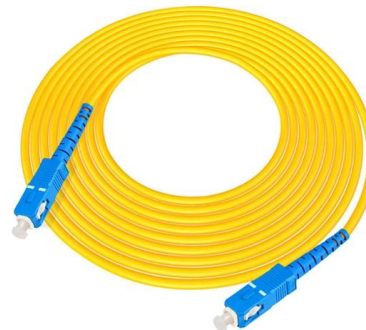

Contact Us

For datasheets, pricing, or custom fiber access solutions, please visit:
<https://frindel.es>