

Arrangement of power distribution boxes and network boxes

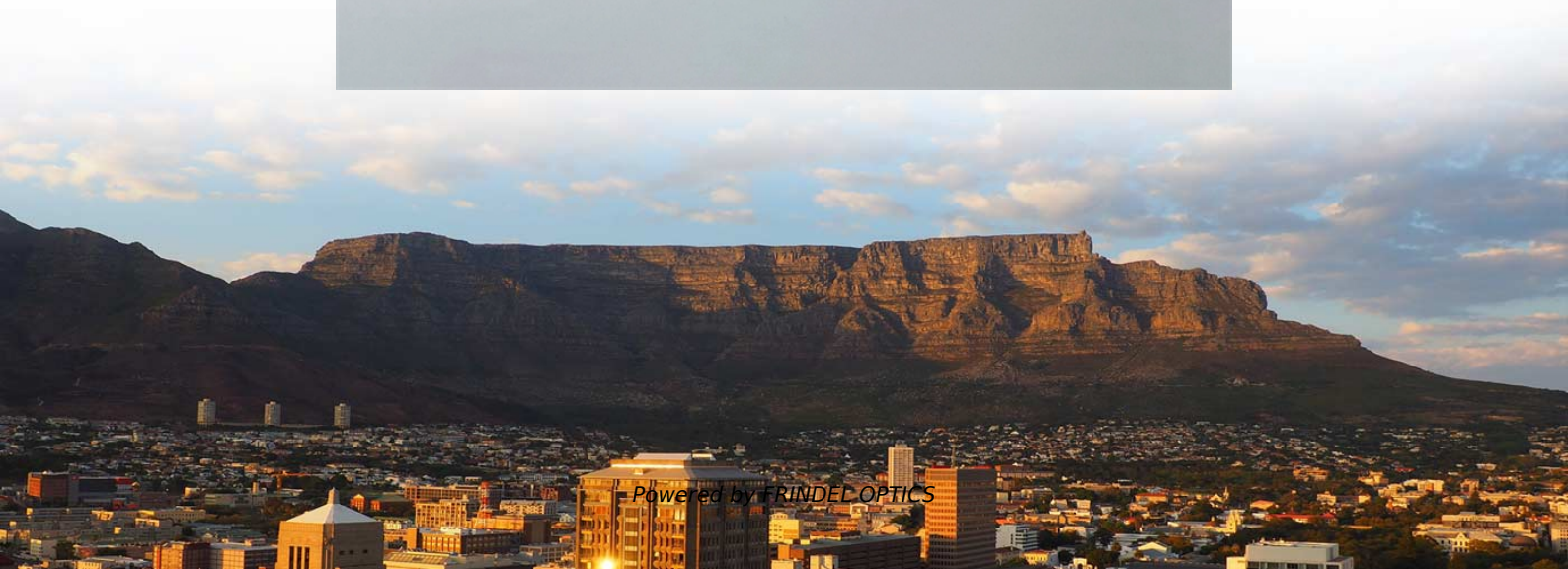



Arrangement of power distribution boxes and network boxes



Understanding Distribution Boxes: Your Guide to Power Distribution

What are the different types of distribution boxes? The table below provides a comprehensive overview of various distribution box types and highlights their key features and

[Contact Us](#)

How Does a Power Distribution Box Work: A Guide

Learn how a power distribution box works, its role in safely managing electricity, and why it's vital for efficiency in industrial and commercial projects.

[Contact Us](#)



Distribution Box: Types and Functions , Axis-Electricals

A distribution box houses all the contact breakers, earth leakage units, doorbells, and timers. The electrical power supply comes from the network to the building

[Contact Us](#)



The installation requirements for the distribution box

A distribution box is the heart of any electrical system. It takes the incoming power and safely distributes it to different circuits throughout your

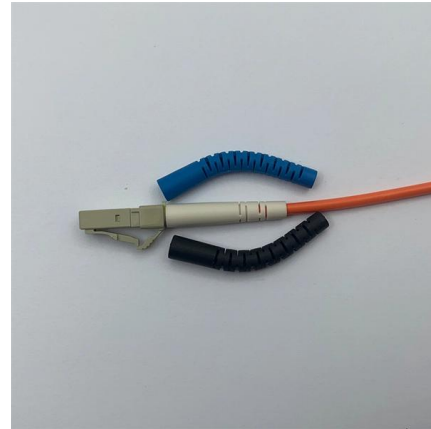

How to Install a Cable Distribution Box Safely and

In modern electrical systems, cable distribution boxes (also known as electrical distribution boxes or distribution boxes) play a crucial role as the key

[Contact Us](#)

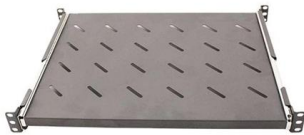

Power Distribution Systems

This section delves into the major components of AC power distribution systems, including distribution lines, distribution transformers, circuit breakers and

[Contact Us](#)

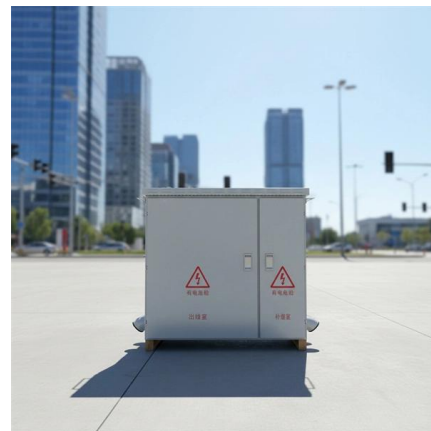

Power Distribution Boxes Explained Simply

Learn what a power distribution box is, how it works, key components, types, and why it's vital for safe and efficient electrical systems.

[Contact Us](#)





Power Distribution Equipment

Introduction Power Distribution Equipment is a term generally used to describe any apparatus used for the generation, transmission, distribution, or control of electrical energy. This section concentrates

[Contact Us](#)



Distribution Boxes Types - The Complete Guide

The power distribution boxes deliver electricity from the main electrical main to other circuits. Several distribution boxes are designed for specific use in

[Contact Us](#)

Electrical Power Distribution System:

Electrical power is the most widely used form of energy because it can be transmitted and distributed far more easily than other forms, such as

[Contact Us](#)



What is a Distribution Box? - A Comprehensive Guide

A distribution box organizes and controls power flow, ensuring safety and efficiency in electrical systems.

[Contact Us](#)



Complete Guide For Distribution Boxes Types

Distribution boxes, also known as electrical distribution boards or panels, are pivotal components in electrical systems, ensuring the safe and organized distribution of

[Contact Us](#)

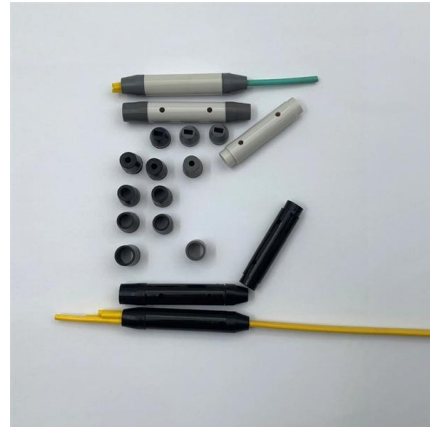

Power Distribution Box Essentials: Functions, Types

Both ordinary distribution and ex-proof distribution power boxes serve the same purpose of safe power distribution, but each is suitable for different

[Contact Us](#)



Understanding Power Distribution Boxes: Types, Features, and

This guide delves into the intricacies of power distribution boxes, shedding light on their design, functionality, and regulatory standards. Readers can expect to gain a comprehensive

[Contact Us](#)



Distribution Box Guide: Types, Components & Solutions

Understand distribution boxes (DB boxes) in 5 minutes. Learn about types, components, functions, and uses. Find the perfect DB box for your needs.

[Contact Us](#)





Ultimate Guide To Distribution Boxes Db Boxes Types

This ultimate guide explains what a distribution box does, its internal components, common types, real-world applications, and how to select the right DB Box for

[Contact Us](#)



Understanding Distribution Boxes: A Comprehensive Guide

Learn what a distribution box is, its types, and how to choose the right one for your project. Includes clear examples and expert tips.

[Contact Us](#)

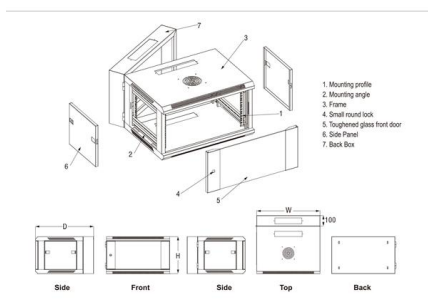

System Arrangements

Several commonly used system topologies are presented here, along with the pros and cons of each. The figures for each of these assume that the distribution and utilization voltage are the same, and

[Contact Us](#)



Size determination, installation method and wiring mode

The distribution box is the central hub of the home circuit and the general control of our daily power consumption. It is an indispensable electrical equipment. If there

[Contact Us](#)



Distribution Box and Selection Guide



Different settings have distinct electrical requirements: Residential: Homes typically require single-phase power and a Distribution Box with fewer

[Contact Us](#)



Distribution Boards

Distribution boards, often referred to as electrical panels or breaker boxes, serve as the nerve center of any electrical system. Here we explore the crucial parts of a distribution board and gain insights into

[Contact Us](#)



Cable Distribution Box Layout: 10 Industrial Strategies

Optimize your cable distribution box layout for safety and efficiency. Learn industrial best practices using Chuanli's IEC-standard outdoor and custom boxes.

[Contact Us](#)



Distribution Boxes: Types and Functions

A distribution boxes acts as the load center and main distributor of electrical power within a building. Also called a distribution board, panel board,

[Contact Us](#)



12 types of distribution boxes and how to choose them

In this guide, we'll break down the 12 main types of distribution boxes in a way that's easy to understand. We'll chat about what each one does, where it shines, and then dive into how to choose the perfect

[Contact Us](#)



Annex I

Signal and power cables are routed in different cables trays according to the type of signal or power. ITER has based its cable distribution on the IEC 61000-5-2 recommendations for Earthing and

[Contact Us](#)

How to Install a Distribution Box--A Comprehensive

An electrical distribution box, also known as a power distribution box, panelboard, or consumer unit, is the core of an electrical system. It has three

[Contact Us](#)



Contact Us

For datasheets, pricing, or custom fiber access solutions, please visit:
<https://frindel.es>