

# **After-sales service CFP82 5G**





## After-sales service CFP82 5G

---



### **Festo Homepage: Reparaturen anfragen im After Sales Portal**

In diesem Festo Tutorial geht es darum, wie Sie Reparaturen im After Sales Portal anfragen. Festo Service - der Kanal rund um das Thema Service und Support.

[Contact Us](#)

### **After-sales services , Epta Central North Europe**

During the lifecycle, our service and maintenance teams provide both a cost-effective and reliable operation over the average product lifecycle. Our on-demand services help ensure sustainability as

[Contact Us](#)



### **EXFO FTBx-88000 SERIES USER MANUAL Pdf**

View and Download EXFO FTBx-88000 Series user manual online. High-Speed Multiservice Test Module. FTBx-88000 Series test equipment pdf manual

[Contact Us](#)

### **After Sales Policy**

Learn about our detailed after sales policy, aimed to ensure customer satisfaction. Understand return policies, warranties, and customer services.

[Contact Us](#)



### **After sales service**

Warranty after purchase Our reputation and success are strongly based on our service, which is proof to our customers and consumers that they made the right decision when choosing TARGA. We are, for

[Contact Us](#)



### **Giftec worry-free global after-sales service!**

In addition to excellent product quality, high-quality and complete after-sales service can provide customers with longer-term value. Giftec has

[Contact Us](#)



### **After-Sales Support Services**

Discover the importance of after-sales support services for your business and how they can benefit your fleet.

[Contact Us](#)





### After Sales Service

After Sales Service Product Training Rather than just developing, producing, and selling medical technology, we offer our partners a complete service, from purchase to after-sales support. Our goal

[Contact Us](#)



### After-sales

Our solutions support the complete after-sales service process, including vehicle reception. Moreover, we provide OEMs with the necessary equipment to test,

[Contact Us](#)

### After Sales Service: How you can increase your revenue

The following approaches illustrate how after-sales service, especially in the machine manufacturing industry, can play a crucial role in maximizing profits, opening up

[Contact Us](#)

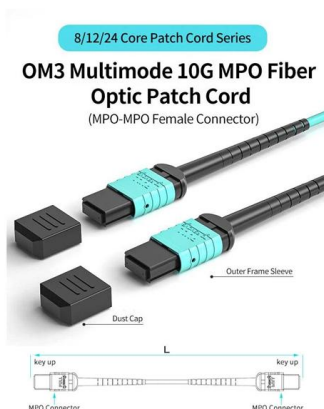

### CFP8 MSA

**WARNING:** In the optional shared MDIO implementation, when a CFP8 module comes out from power-up or reset, including after hot-plug into an operating host, the host must ensure that there is no bus

[Contact Us](#)



## XENTRY Portal

XENTRY Portal provides access to Mercedes-Benz after-sales services and solutions for workshops and professionals.

[Contact Us](#)

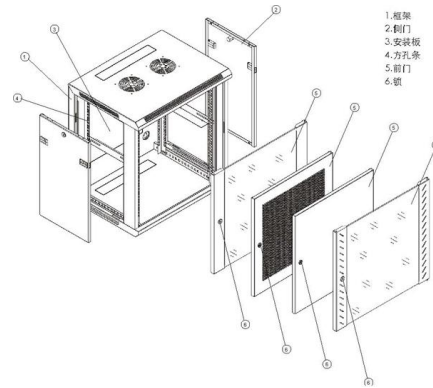

## After-Sales Service

**AFTER-SALES SERVICE** Your complete service provider For over 55 years, the FRIMO brand has stood for production equipment of outstanding quality. To ensure the best results with your systems

[Contact Us](#)

## Technischer Kundendienst für Leistungselektronik , TRUMPF

Unser Kundendienst hilft Ihnen kompetent bei allen After-Sales-Fragestellungen. Hierfür unterhalten wir eigene Serviceniederlassungen in Europa, Asien und USA.

[Contact Us](#)



## Aftersales

ZF Marine Propulsion Systems is dedicated to providing our customers the best possible service, either on-site at your location or at one of our Competence Centers or Service Points. Our factory trained

[Contact Us](#)

## After sales service



You can find our after-sales specialists in many places across the globe. How you benefit: wherever you may need our assistance and support, there will be a highly qualified BMA service technician near you!.

[Contact Us](#)



### Geely Care+

Geely Care+ delivers professional, reliable service with global standards and genuine care. More than maintenance, it's your trusted mobility companion--always for you.

[Contact Us](#)

### After Sales Services bei CLEMENS GmbH

For the products we manufacture, we also offer an after-sales service, and experienced staff attends to our customer needs. Our services are:

[Contact Us](#)



### Spare Parts & Repair

Spare Parts & Repair Customer satisfaction and service play a key role at BITZER. We provide you with an overview of our services in spare parts and repair.

[Contact Us](#)



## AFTER-SALES SUPPORT

The one-of-a-kind, on-the-ground support network delivers expert service, integrated solutions, after-sales support, fast and efficient parts fulfillment, world-class remanufacturing capabilities and more.

[Contact Us](#)



## After-sales service , Böllhoff

Our after-sales solutions are divided into three areas - service, training and repair. These are closely interlinked and have a common goal: supporting you worldwide.

[Contact Us](#)

## After Sales Service , First-class services for blowers and

After Sales Service: PILLER guarantees complete, first-class service worldwide to ensure smooth, professionally supported operation

[Contact Us](#)

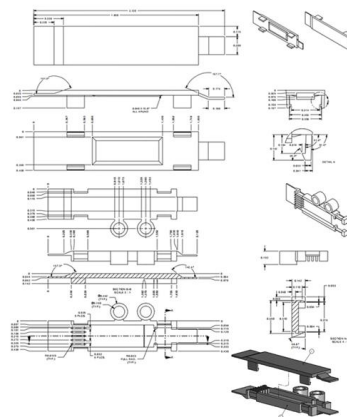

## After-sales support

All-round service. From the design of a complete compressor room to after-sales service, we support our customers worldwide by offering integrated systems for

[Contact Us](#)



## After Sales Service: Definition und Maßnahmen

Der After Sales Service bezeichnet sämtliche Aktivitäten und Dienstleistungen eines Unternehmens, die nach dem Kauf eines Produkts oder einer Dienstleistung erbracht werden.

[Contact Us](#)



## After sales service for standard pumps , Support , EBARA

Operation & Maintenance Service EBARA provides an Operation & Maintenance Service to ensure the smooth operation of our customers' pumps. When a customer takes on an EBARA product, we

[Contact Us](#)

## After-Sales

Wir begleiten Ihr Produkt über den Produktionszeitraum hinaus, um somit dessen Langlebigkeit sicherzustellen und unterstützen Sie in den Bereichen Ersatzteilbeschaffung, Retrofitting,

[Contact Us](#)



## AFTER-SALES SERVICES

Fincantieri's After-Sales Services Division leverages over two centuries of experience in naval defense to deliver top-level technologies, infrastructure, design, support, and assistance, maximizing the

[Contact Us](#)



## After Sales Service

After Sales Service Inspections, maintenance and repairs for safe plant functioning Flexibility, quality and technical competence SCHRADER places great importance on inspections, servicing and

[Contact Us](#)



## 24/7 Emergency Response Help & Support

Service Support For help with: After Sales Service  
All Service related inquiries to new products  
Maintenance Warranty

[Contact Us](#)

## Contact Us

---

For datasheets, pricing, or custom fiber access solutions, please visit:  
<https://frindel.es>