

Activating Optical Fiber Core Resources





Activating Optical Fiber Core Resources



Optical Fiber Core

An optical fiber core is defined as the central region of an optical fiber where light is transmitted, with multicore fibers featuring multiple such cores that propagate light modes independently, allowing for

[Contact Us](#)

Optical Fiber Resource Center

Welcome to the Corning Optical Fiber Resource Center, where you will find a comprehensive library of available resources and materials. Whether you are

[Contact Us](#)

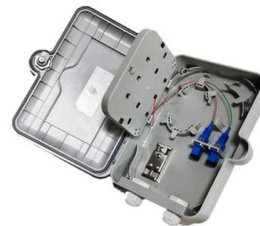

Multi-Core Optical Fibers: Theory, Applications and

Multi-core fibers (MCFs) have sparked a new paradigm in optical communications, as they can significantly increase the Shannon capacity of

[Contact Us](#)

Routing, modulation, core and spectrum assignment techniques for

Multi-core fiber (MCF) based space-division multiplexed elastic optical networks (SDM-EON) is a promising technology to scale the capacity of optical transport networks. MCF-based SDM

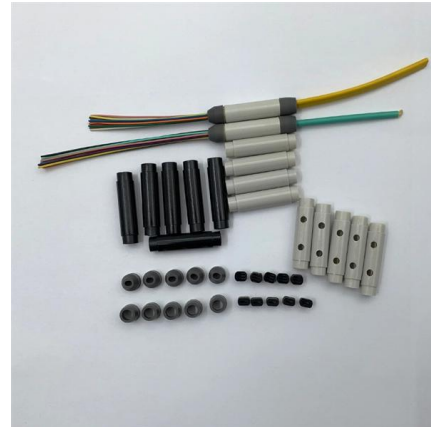

Optical Fiber Core

On top of optical fiber with a sensing element, an OFS setup typically consists of a light source, optical fiber path components, such as an optical circulator or coupler, and some light detector, such as a

[Contact Us](#)



How to Choose the Suitable Number of Fiber Cores for

When planning your fiber optic network, various factors must be evaluated to ensure optimal performance and scalability. The following sections

[Contact Us](#)

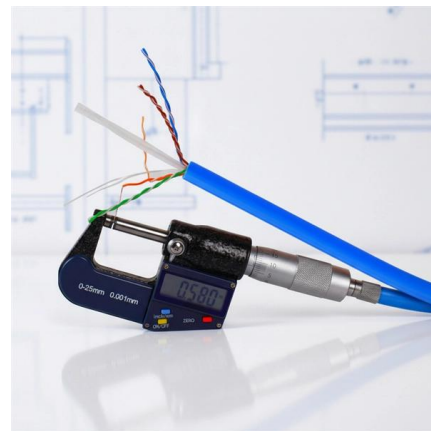

Fiber Core - optical fiber, dopant ions, off-centered core

The fiber core is the region in an optical fiber which guides light. It usually exhibits an increased refractive index.

[Contact Us](#)





Improved Performance of Optical Fiber Core: Role of

Irrespective of the type of metal activation in the fiber core, the refractive index of LP01 mode for the core of radius 200 nm was more

[Contact Us](#)



Routing, modulation, core and spectrum assignment techniques for

Depending on the severity of inter-core crosstalk, we emphasize the importance of designing suitable resource allocation techniques, such as core selection, spectrum slot finding and

[Contact Us](#)



Strategies and tools for large-scale fiber deployment

Fiber network deployment involves complex planning, precise execution, and seamless activation to meet growing digital demands. This guide highlights essential strategies and tools to ensure

[Contact Us](#)

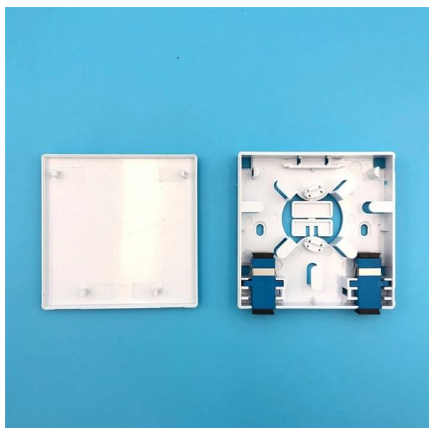

Optical Fiber Core

An optical fiber core is defined as the central region of an optical fiber that guides light, typically surrounded by cladding. In the case of no-core fiber (NCF), it lacks a traditional core structure,

[Contact Us](#)



Multicore Fiber (MCF): Revolutionizing Data Density

Discover how Multicore Fiber (MCF) and Space-Division Multiplexing (SDM) are solving the bandwidth crisis. Learn about MCF applications and how

[Contact Us](#)



Monolithic High-Power Large Mode-Area Fiber Amplifiers

In this paper we outline the recent progress on standardizing LMA fibers and the developments of the relevant couplers, pump sources, connectors and high-power endcaps for developing monolithic (all

[Contact Us](#)

Optical Fiber Core

POFs have a large core, usually made from polymethyl methacrylate (PMMA) and a thin fluorinated polymer cladding. Other types of POF core materials have been developed, such as polystyrene and

[Contact Us](#)



Fiber Optic Basics

Fiber Optic Basics Optical fibers are circular dielectric wave-guides that can transport optical energy and information. They have a central core surrounded by a

[Contact Us](#)



Installation and Activation of Fiber To The Home (FTTH) Networks and

Core (core) The core is the main part of a fiber optic cable which is located right in the middle of the cable, is shaped like a cylindrical rod and is made of high quality fine glass fiber and is

[Contact Us](#)

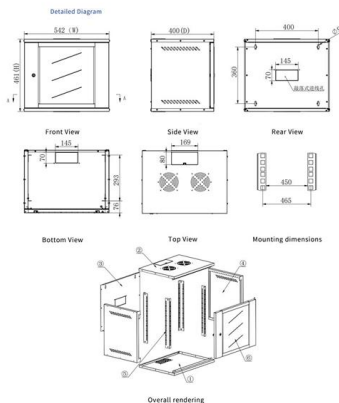

Optical fibers: cladding and core

The core is wrapped in cladding also made from glass fiber or plastic. Two further layers - first the buffer and then the outer jacket - protect the fibers against

[Contact Us](#)

Physical Layer-Aware Routing, Spectrum, and Core Allocation in

Abstract--In this work, efficient routing, spectrum, and core allocation (RSCA) techniques are proposed for spatial division multiplexed (SDM) elastic optical networks (EONs) utilizing multicore



[Contact Us](#)



Applications and Development of Multi-Core Optical

In the following decades, scientists continued to explore and investigate multi-core optical fibers from theoretical, fabrication, and application

[Contact Us](#)



How to Choose the Suitable Number of Fiber Cores for

When designing or upgrading your network infrastructure, one of the most important decisions you'll face is choosing the appropriate number of fiber

[Contact Us](#)



Hollow core fiber: power and precision for critical networks

As fiber-optic networks must continuously adapt to the exponential growth of data while maintaining low latency, a new technology is emerging on

[Contact Us](#)



Applications and Development of Multi-Core Optical Fibers

In this paper, an overview of the current status and future prospects of multi-core fiber manufacturing technology has been presented, and their limitations will be discussed.

[Contact Us](#)



How the Core of a Fiber Optic Cable Works

Unlock the physics of Total Internal Reflection and the core design choices that power the global fiber optic communication backbone.

[Contact Us](#)

All-fiber architecture for high speed core-selective switch

In this work, we present an all-fiber architecture



for a high-speed core-selective switch, crucial for efficient signal distribution in multicore networks.

[Contact Us](#)

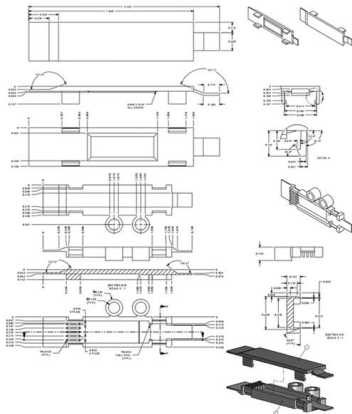

Lineup of multi-core optical fiber construction, operation, and

Because the four-core MCF is as thin as the existing optical fiber, the outer diameter of the MCF cable can be unified with that of the existing optical fiber cable, and the basic structure of

[Contact Us](#)

Fiber Optics Fundamentals: Construction, Transmission,

Explore fiber optic cable design, transmission principles, and performance optimization techniques. Ideal for engineers designing high-reliability

[Contact Us](#)



Astroneer How To Activate Core Easy Way

This is the simplest way to activate a planet's core. Here are the steps:1. Pave roads to all the surface nodes. Pay attention to which one is closest to you

[Contact Us](#)





Semiconductor core fibres: materials science in a bottle

Novel core fibers have a wide range of applications in optics, as sources, detectors and nonlinear response media. Optoelectronic, and even electronic device applications are now possible,

[Contact Us](#)

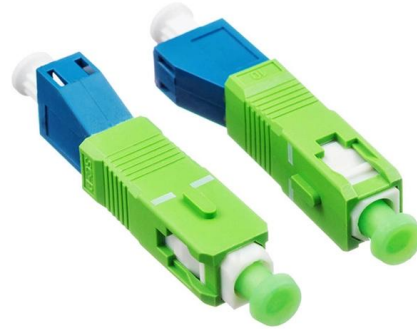

NCTI Fiber Install & Activation Flashcards , Quizlet

Study with Quizlet and memorize flashcards containing terms like Which standards organization is considered the creator of the world's most recognized communications standards, known as

[Contact Us](#)

Contact Us

For datasheets, pricing, or custom fiber access solutions, please visit:
<https://frindel.es>