

ASEAN Explosion-proof Distribution Box Service Hotline

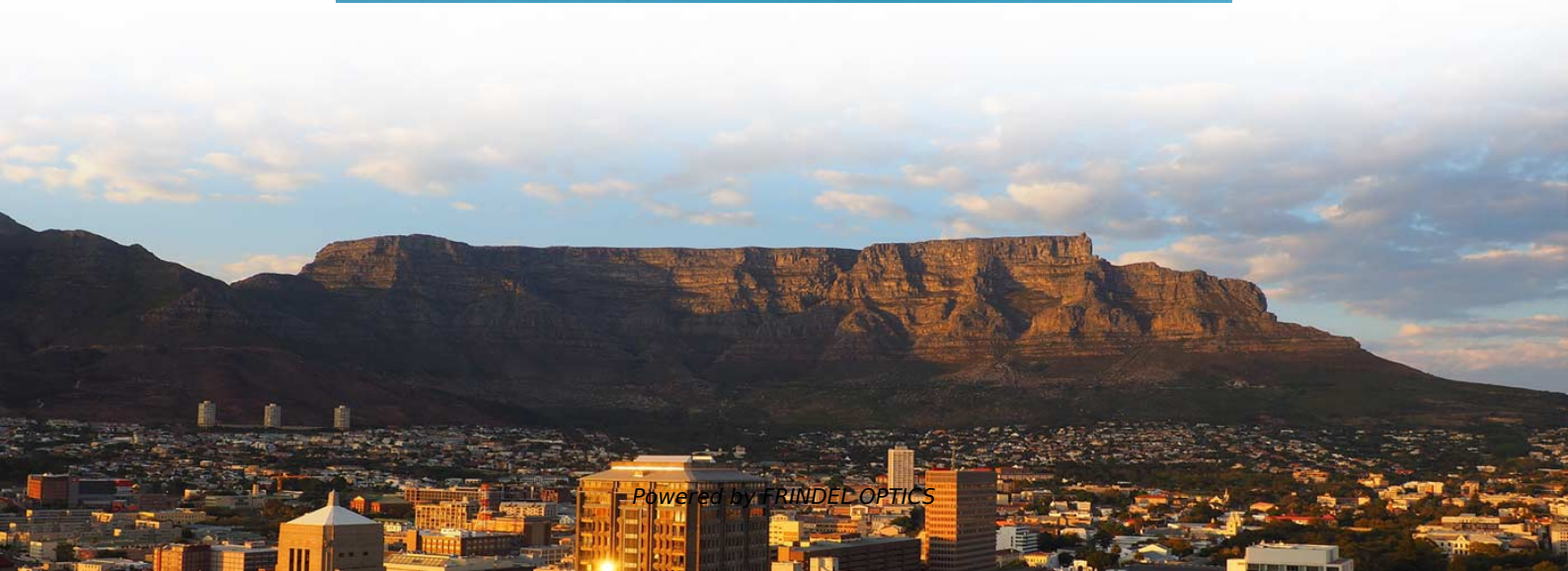



ASEAN Explosion-proof Distribution Box Service Hotline



Explosion-proof distribution box: the "invisible guard" protecting

Ordinary distribution boxes may become a safety hazard in high temperature, corrosive or flammable environments. The explosion-proof distribution box uses explosion-proof, anti

[Contact Us](#)

Explosion proof distribution box standards and installation issues

I. Explosion-proof distribution box general standards Distribution box production technology indicators to meet the specifications and design requirements, and in accordance with the provisions of the

[Contact Us](#)



Explosion-Proof Electrical Distribution Boxes: Applications in

An explosion-proof distribution box is a specialized enclosure designed to contain internal explosions and prevent the escape of flames, sparks, or hot gases. It is essential to note that these boxes are

[Contact Us](#)

Explosion proof junction box, explosion-proof distribution box

Buy Explosion proof junction box, explosion-proof distribution box, explosion-proof box, explo online today! Dear Sir/Madam, Thank you for visiting our store! ?The quality of our products is original

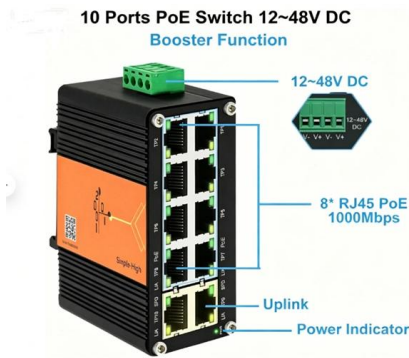
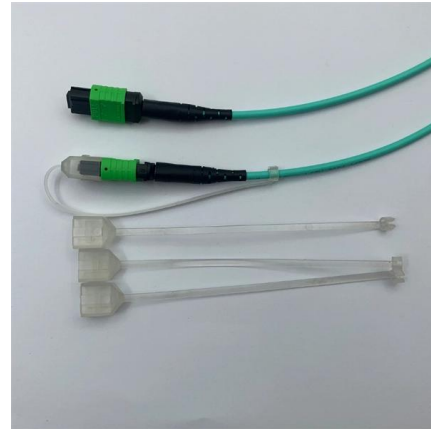

Explosion-Proof Distribution Box

The distribution box (explosion-proof) is an aluminum alloy housing, electrostatic spraying, in accordance with the explosion-proof provisions of GB3836.2-2000, for the distribution of electric

[Contact Us](#)

Explosion-proof Distribution Box Manufacturers

Explosion-proof Distribution Box Manufacturers, Factory, Suppliers From China, We, with open arms, invite all interested potential buyers to visit our web-site or get in

[Contact Us](#)

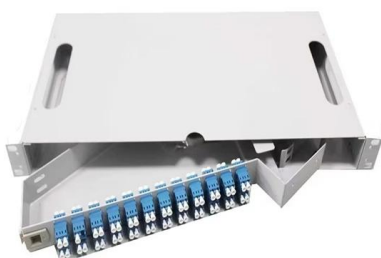

EXPLOSION PROOF DISTRIBUTION BOX - Lapex

Lapex delivers explosion proof lights, fans, panels, and cable glands engineered to global safety standards. With certified products and reliable service, we ensure protection and performance in

[Contact Us](#)

Distribution box solutions for explosion-proof environments in



Explosion-proof distribution boxes represent where regulatory wisdom meets engineering excellence. What appears as simple protective enclosures are actually sophisticated safety systems honed

[Contact Us](#)



Explosion proof Power Distribution Panel Box

Power Distribution panel box - Hazardous locations for explosive gas mixtures: Zone 1 and Zone 2. Explosive gas mixtures: Class IIA, IIB, and IIC.

[Contact Us](#)



Explosion Proof Distribution Boxes

BXM (D)51 Series (Click on the text for more information) explosion proof distribution boxes, BXM, BXM (D)8050, BXM (D)8050 series, BXM (D)51, BXM (D)51 series, BXB (D)53, BXM

[Contact Us](#)



Explosion-Proof Distribution Box , Safe Power Control - DDY GROUP

Keep the box clean and check components as part of routine care. Take control of your electrical safety today with this complete set of customized distribution boxes. Choose an explosion-proof distribution

[Contact Us](#)





Exd IIC Explosion Proof and Anti-Corrosion Distribution Box 8 Holes

Our main products are explosion-proof lightings, explosion-proof distribution box, explosion-proof cable gland, explosion-proof fans, explosion-proof junction box and anti-corrosion & dustproof & waterproof

[Contact Us](#)



HRMD92 Explosion proof Distribution Box (Ex d IIB+H2)

Warom Explosion proof Distribution Box (Ex d IIB+H2) in 316 stainless steel. Available with a wide range of built in components.

[Contact Us](#)

Premium Explosion-Proof Distribution Boxes , Safe & Reliable

Explore our selection today to find the perfect solution for your electrical distribution needs, and ensure the safety of your workplace. Trust in our expertise and commitment to quality for all your explosion

[Contact Us](#)

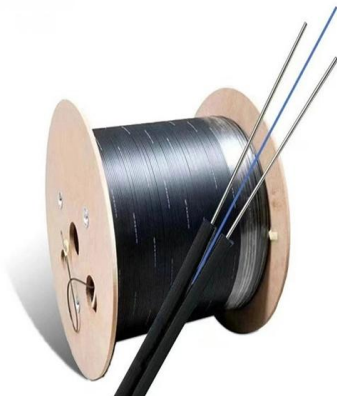

How to Wire an Explosion-Proof Distribution Box and

Explosion-proof electrical equipment, such as explosion-proof distribution boxes, is specifically designed for hazardous environments where flammable gases,

[Contact Us](#)

Precautions for installation of explosion



proof power distribution box

3. Explosion proof distribution box and switch box shall be installed in ventilated, dry and normal temperature places. It is strictly forbidden to install it in the gas, smoke, steam, liquid and

[Contact Us](#)

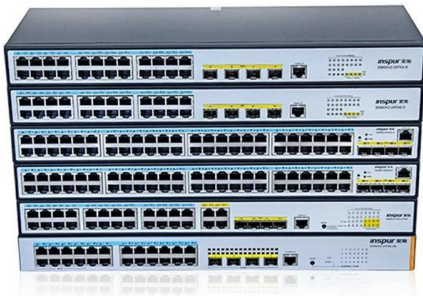

Explosion Proof Illumination Distribution Boxes (With

Flameproof and explosion proof, these power overhaul distribution boxes are suitable for use in hazardous areas. Specs: Ex mark: Ex de IIC T4 Gb DIP A21 TA,T4

[Contact Us](#)

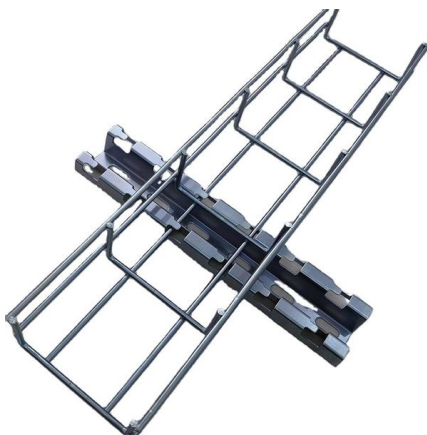

Power Distribution Box Explosion-Proof Power

Power Distribution Box Explosion-Proof Power Distribution Cabinet, Find Details and Price about Power Distribution Cabinet Explosion-Proof Power Distribution

[Contact Us](#)



Evaluating Chinese Explosion Proof Distribution Box Suppliers

Technical support services and after sales support for explosion proof solutions are equally important for long-term operational success of hazardous area equipment. This includes

[Contact Us](#)



BM (D)X-Series Explosion Protected Distribution Box

BM (D)X-Series Explosion Protected Distribution Box Explosion protection -IECEX (IEC) -ATEX (CENELEC,EN) -China Ex (GB) Application in hazardous area

[Contact Us](#)



Ex Isolation Switch/Safety Switch/Circuit Breaker Manufacturers

CZ Electric Co., Ltd is an Explosion-proof isolation switch manufacturers and Explosion-proof safety switch, Explosion-proof circuit breaker (MCB) box factory.

[Contact Us](#)

Explosion Proof Enclosure

Junction Box Enclosure suitable for use in Zone 1 & 2 areas. Available in Plastic (GRP / FRP), Aluminium & Stainless Steel SS316 / SS304 Material.

[Contact Us](#)



Explosion-proof Distribution Box

China Explosion-proof Distribution Box catalog of Anti-Corrosion Electrical Control Box 6 Holes Aluminum The Explosion-Proof Distribution Box Power Instrument Box Industry Water, Exd lic

[Contact Us](#)



IP66 Explosion Proof Distribution Boxes for Hazardous Areas

Shop high-quality IP66 explosion proof distribution boxes for safe and reliable electrical installations in hazardous areas. Find durable, customizable solutions now.

[Contact Us](#)



Explosion Proof Distribution Box , ATEX Transformer Supplier

We supply certified explosion proof distribution box & ATEX Transformer -Appleton, ATKON, CZ, CEAG, brands for safe and reliable industrial use.

[Contact Us](#)



Custom CZ1290 Explosion-proof distribution boxes

Besides the present designation for the full plastic explosion-proof mobile power branch connection socket box, it also can be designed and manufactured

[Contact Us](#)



Evaluating Chinese Explosion Proof Distribution Box Suppliers

Selecting the right Chinese explosion proof distribution box supplier is a critical decision for any industrial operation involving hazardous environments. This choice directly impacts the

[Contact Us](#)





Explosion-Proof Distribution Box , Product Center

Explosion-proof distribution boxes are designed to safely control and distribute electrical power in hazardous environments, preventing ignition risks.

[Contact Us](#)

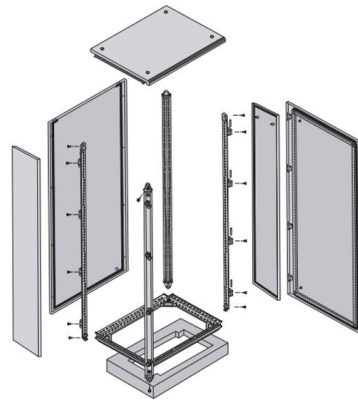

Contact Us

For datasheets, pricing, or custom fiber access solutions, please visit:
<https://frindel.es>