

3dB Coupler in Optical Switch





Overview

Essentially, it's an optical device used to split or couple light from one optical fiber or waveguide to another, equally distributing the input signal—hence the term "3dB" that signifies a 50% split in power. κ is a function of the waveguide geometry, separation and physical parameters Example: For $\kappa l = (2m+1)\pi/4$, and m is a nonnegative integer, power at the input will be split. Hamed Nikbakht, Mohammad Talebi Khoshmehr, Bob van Someren, Dieter Teichrib, Manfred Hammer, Jens Förstner, and B. Imran Akca Here we demonstrate a new, to the best of our knowledge, type of 3-dB coupler that has an ultra-broadband operational range from 1300 to 1600 nm with low fabrication. Optiwave software can be used in different industries and applications, including Fiber Optic Communication, Sensing, Pharma/Bio, Military & Satcom, Test & Measurement, Fundamental Research, Solar Panels, Components / Devices, etc. The fabricated switch has shown 120 nm optical bandwidth with more than 15 dB extinction ratios.



3dB Coupler in Optical Switch



Broadband Graded Index 3dB Adiabatic Coupler for Photonic

In this study, we present a novel graded index (GI) 3dB adiabatic directional coupler utilizing polymer material. Our design prioritizes both fabrication flexib

[Contact Us](#)

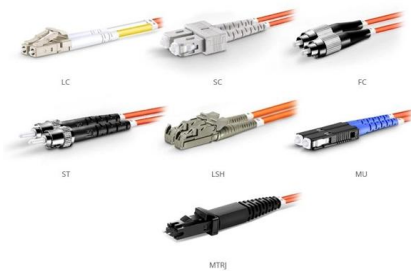

OM1 Fiber Patch Cable Family

Broadband multimode 3dB optical power splitter using

Abstract A design of a 1×2 multimode 3 dB optical power splitter using tapered couplers is proposed and investigated in this paper.

[Contact Us](#)

A Broadband Optical Switch Based on Adiabatic Couplers

Abstract We designed and fabricated a broadband thermo-optic Mach-Zehnder Interferometer switch using two 3-dB adiabatic couplers on the 500 nm Silicon-On-Insulator platform. The fabricated switch

[Contact Us](#)



What Is Fiber Optic Coupler and How Does It Work?

Fiber optic couplers are used to split or combine optical signals in optical fiber systems. It contains various types like optical splitters, optical

[Contact Us](#)



2. Imported design is convenient for expansion.

The design of two inlets saves space and allows for rear line entry.

Broadband and fabrication-tolerant 3-dB couplers with

To address this, we introduce topological physics to nanophotonics, developing a framework for topological 3-dB couplers. These couplers exhibit broad working wavelength range and

[Contact Us](#)



Mode-insensitive 3-dB power splitter based on multimode-interference

In the reported arts, the 3-dB optical power splitter based on directional coupler structure is wavelength-sensitive, there are many methods for optimizing directional coupler structure, including

[Contact Us](#)

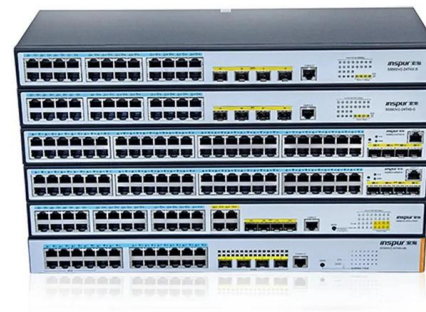

Lesson 6: Design a 3dB Coupler using VB Script

OptiBPM is a comprehensive CAD environment used for the design of complex optical waveguides. Perform guiding, coupling, switching, splitting, multiplexing, and demultiplexing of optical signals in

[Contact Us](#)





Compact and robust 2 × 2 fast quasi-adiabatic 3-dB couplers on SOI

We design and experimentally demonstrate compact and robust fast quasi-adiabatic (FAQUAD) couplers for silicon-on-insulator (SOI) strip waveguides.

[Contact Us](#)



ARXIV_new

In this work, we experimentally demonstrate a new type of a 3-dB optical coupler that works over the 1300-1600 nm wavelength range.

[Contact Us](#)

Lecture13_228B_W06_Final.ppt

Example: For $\beta l = (2m+1)\pi/4$, and m is a nonnegative integer, power at the input will be split evenly between the two output ports. This is also known as a 3-dB coupler. Note that for a signal incident at



[Contact Us](#)



Broadband polarization/mode insensitive 3-dB optical coupler for

In this work, we experimentally demonstrate a four-mode polarization/mode insensitive 3-dB coupler based on an adiabatic coupler. The proposed design works for the first two transverse

[Contact Us](#)



Optical Coupler

The optical couplers can be used to create more complicated optical devices, such as $M \times N$ optical stars, directional optical switches, different optical filters, and multiplexers.

[Contact Us](#)

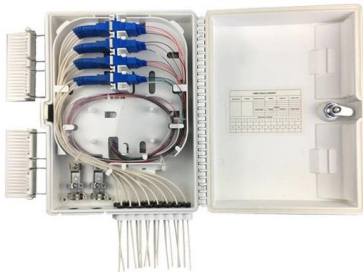

A Broadband Optical Switch Based on Adiabatic Couplers

In this work, we demonstrate a robust MZI switch design with 3-dB adiabatic couplers. A 3-dB adiabatic coupler has been shown to be inherently 50% power splitting and highly insensitive to wavelengths

[Contact Us](#)

Asymmetric, non-uniform 3-dB directional coupler with

The coupler is an asymmetric non-uniform directional coupler that consists of two tapered waveguides. One of the coupler arms is shifted by $100 \mu\text{m}$ in the

[Contact Us](#)



An ultra-broadband, and low loss 3-dB optical power splitter with

This paper proposes and demonstrates a new design for a 3-dB optical power splitter with curvature optimized adiabatic taper which can achieve ultra-broadband operation, low loss, compact,

[Contact Us](#)



Microsoft Word

Abstract--This paper reviews the basic of multimode interference (MMI) coupler and its application in optics, especially for optical switching. We have demonstrated the design & performance of 2

[Contact Us](#)



ARXIV_new

We also experimentally demonstrated an optical switch that is made by using two of these couplers in a Mach Zehnder interferometer configuration. According to experimental results, this optical switch

[Contact Us](#)

High-Performance and Fabrication-Tolerant 3 dB

However, in large-scale optical switches and neural networks, the extensive use of splitters exacerbates insertion loss and crosstalk, thus degrading

[Contact Us](#)



Fiber Optic Couplers Information

Fiber optic couplers are optical devices that connect three or more fiber ends, dividing one input between two or more outputs, or combining two or more inputs

[Contact Us](#)



Theoretical analysis: the performance of 3dB optical

Theoretical analysis: the performance of 3dB optical coupler in changing the refractive index. The fabricated 3dB couplers were exposed at high temperature

[Contact Us](#)

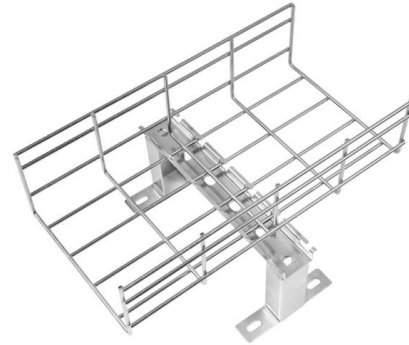

3dB Couplers in Optical Components

Directional couplers are optical components used to combine and split optical signals in a network. They consist of two input and two output ports. Most commonly, two optical fibers are fused together to

[Contact Us](#)

Power dividers and directional couplers

A symbol for power dividers is shown in figure 2. Power dividers and directional couplers are in all essentials the same class of device. Directional coupler tends

[Contact Us](#)

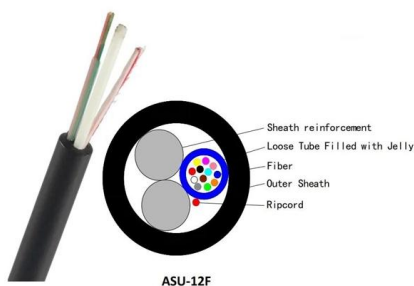

Understanding 3dB Couplers in Optical Communication

To define a 3dB coupler is straightforward. Essentially, it's an optical device used to split or couple light from one optical fiber or waveguide to another, equally

[Contact Us](#)

Hybrid Couplers



Find & Compare RF Hybrid Couplers - 90 Degree Hybrid Couplers, 180 Degree Hybrid Couplers and other hybrids from multiple manufacturers on everything RF.

[Contact Us](#)

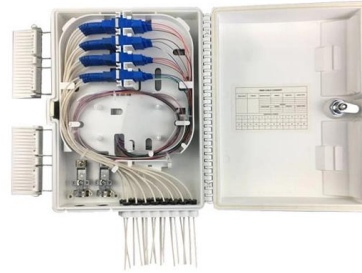

Design of All-Optical Directional Coupler Using Plasmonic

The proposed 10-dB directional coupler and 3-dB directional coupler feature good energy confinement, ultra-compact, and low propagation loss, which has potential applications in photonic

[Contact Us](#)



Broadband and fabrication-tolerant 3-dB couplers with

By bridging topology with nanophotonics, we realize on-chip topological 3-dB couplers with the superiority on the broad bandwidth of 48 nm and the tolerance against dimensional errors of

[Contact Us](#)

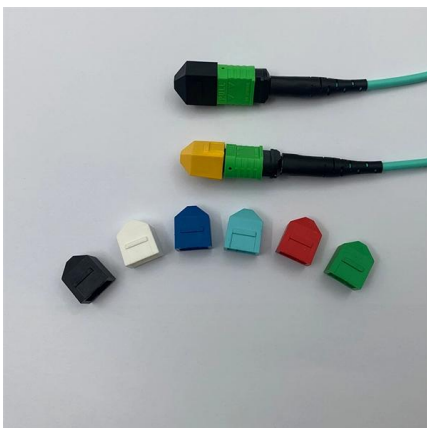

Implementation of all-optical 3-dB and 10-dB directional coupler for

AbstractThe design of an all-optical 3-dB and 10-dB directional coupler that functions as an optical switch if applied a control signal by fusing two photonic crystal waveguides with a coupling

[Contact Us](#)



Implementation of all-optical 3-dB and 10-dB directional coupler for

The design of an all-optical 3-dB and 10-dB directional coupler that functions as an optical switch if applied a control signal by fusing two photonic crystal waveguides with a coupling

[Contact Us](#)



Contact Us

For datasheets, pricing, or custom fiber access solutions, please visit:
<https://frindel.es>